

Hall Effect Voltage Sensor VH1K0T02

V_{pn} = 1000 V

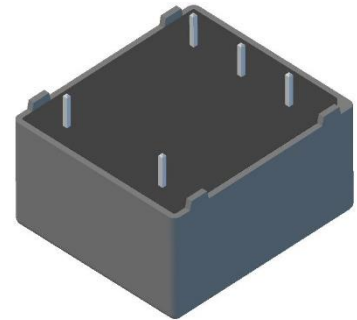

Features

- . Closed loop voltage sensor
- . Through hole PCB mounting type
- . current output.

Advantage

- . Excellent accuracy
- . Very good linearity
- . Low temperature drift
- . Optimized response time
- . Wide frequency bandwidth
- . No insertion losses
- . High immunity to external interference
- . Current overload capability.

Applications

- . Used for the measurement of electric voltage, AC, DC
- . Pulsed in Electrical & Electronic equipment.

Application domain

- . Commercial
- . Industrial

Maximum ratings

Parameter	Symbol	Value	Unit
Maximum supply voltage (working) -40 to 85°C	$\pm U_c$	$\pm 15V$	V
Primary conductor temperature	T_s	85	°C
maximum steady state primary Voltage -40 to 85°C	V_{PN}	1000	V
Dielectric Strength between Pri to Output terminal	V_w	2.5	KV
Comparative Tracking Index	CTI	600	V
Insulation Resistance	R_{is}	≥ 100	MΩ

Electrical data

VH1K0T02

Parameter	Symbol	Condition	Min	Typ	Max	Unit
Primary Nominal Rms Voltage	V_{PN}			1000		V
Primary Voltage, Measuring Range	V_P			± 1500		V
Primary Nominal Rms Current	I_{PN}			10		mA
Primary Current, Measuring Range	I_P			± 14		mA
Burden Resistance	R_b	@ $I_{PN} = \pm 10\text{mA}$	150		340	Ω
		@ $I_{PN} = \pm 14\text{mA}$	150		250	Ω
Resistance Of Secondary Winding	R_s	@ 70 °C		55		Ω
Resistance Of Primary Winding	R_p	@ 70 °C		190		Ω
Output Current at I_{PN}	I_{out}			25		mA
Number Of Secondary Turns	N_s			2500 :		
				1000		
Supply Voltage	$\pm U_c$	10% variation		± 15		V
Current Consumption	I_c	$\pm U_c = \pm 15\text{ V}$		$11 + I_{out}$		mA
Temperature Variation Of I_o , Referred to Primary	I_{OT}			≤ 0.4		mA
Output offset current @ $I_{PN} = 0$	I_{OFF}			± 0.20		mA
Linearity Error	Σ_L	-40 to 85 °C		<0.2		% of I_{PN}
Overall Accuracy At I_{PN}	X_c	@-40 to +85°C		< ± 0.8		% of I_{PN}
Creepage distance				19.5		mm
Clearance distance				19.5		mm
Ambient Operating Temperature	T_A		-40		+85	°C
Ambient Storage Temperature	T_S		-40		+90	°C
Mass	m			30		g

Connection Diagram

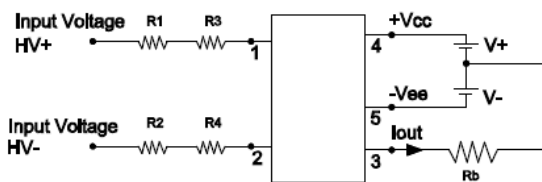

Input Output Characteristics

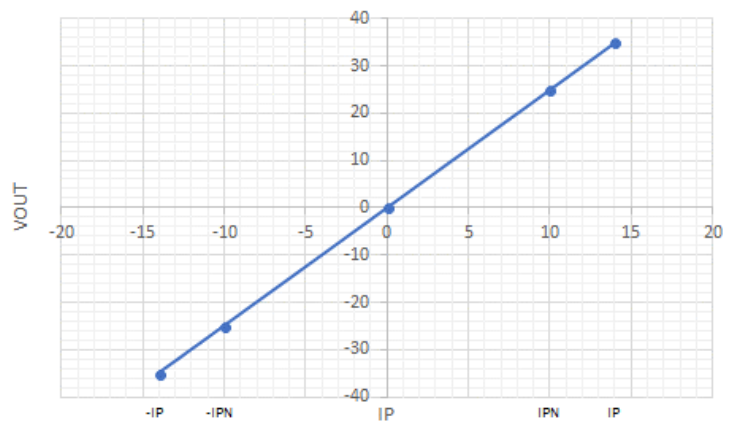

Mechanical dimensions are in mm

Tolerance: ± 0.5 mm

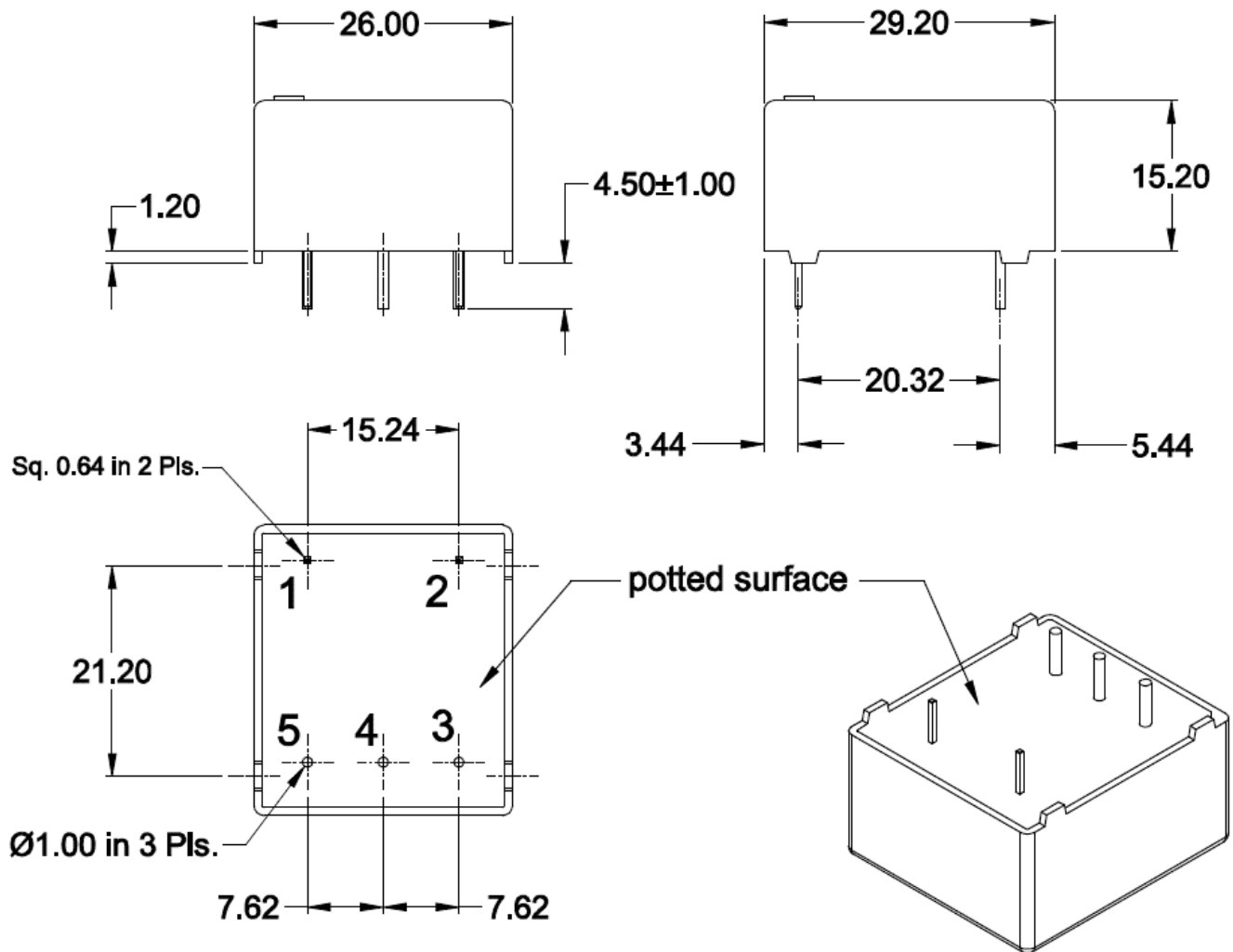

Pin Out	Name
1	+Ve
2	-Ve
3	Output
4	+VCC
5	-VCC

Safety

General Data

- The housing and insulation resin (UL94 V0) are self-extinguishable upon fire
- Mounting holes are provided in the housing mold for base mount, 2 fastening slots of \varnothing 6.5 mm
- Direction of current: a positive primary differential potential (UHT+ - UHV- >0) generates a positive secondary output current on terminal output
- Power supply is protected against polarity reversal

Wiring and mounting instructions

These general instructions are not exhaustive and provide basis for proper installation of the sensors. Each configuration being different, please consult us for advice. (Note that non-proper installation or incorrect use of the sensor can result in sensor poor performances or malfunction)

Wiring diagram

- Connect primary voltage V_p to measure to HV+ and HV-
- Auxiliary supply voltage: bipolar voltage -VEE...0 V...+VCC

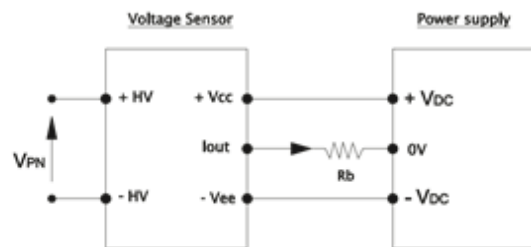

Precautions in electromagnetic environment

Due to their principle of operation (measure of magnetic field by the Hall effect probe), closed loop hall effect current sensors can be sensitive to strong magnetic fields. It is recommended to avoid positioning them too close to high current power cables.

Processing of the sensor output signal

Standard codes of practice advise that, before the signal is processed, a low-pass filter adapted to the bandwidth of the sensor is used. Also, in the case of digital processing of the signal, it is also recommended that the sampling frequency is adapted to the bandwidth of both the signal to be measured and the sensor.

In the event of sensor failure, the processing of the output signal should consider deterioration in performance (i.e. absence of signal or saturated signal) and rapidly and safely shut the system down.

Safety instructions



Our sensors must be used in electrical or electronic equipment with respect to relevant standards and safety requirements in accordance with the manufacturer's operating instructions



Caution, risk of electrical shock

When operating the sensor, certain parts of the module can carry hazardous voltage (e.g. primary terminals, power supply). Ignoring this warning can lead to injury and/or cause serious damage.

This sensor is a built-in device, whose conducting parts must be inaccessible after installation. A protective housing or additional shield could be used. Main supply must be disconnected