

## Features

- Bipolar and isolated measurement up to 1500V
- Current output
- Input and output connections with tab terminal

## Advantage

- Compact design
- Excellent accuracy (offset, sensitivity, linearity)
- Good response time
- Low temperature drift

## Applications

- Single or three phase inverters
- Propulsion and braking chopper
- Auxiliary converter
- High power drives
- Substations

## Application domain

- Traction
- Industrial

## Standards

- EN 50178
- UL508

## Insulation characteristics

Parameters	Symbol	Value	Units
Dielectric strength between primary and secondary terminals, 50Hz, 60seconds	$V_d$	4.1	kV
Comparative tracking index	CTI	175	V
Insulation resistance	$R_{is}$	$\geq 100$	$M\Omega$
Creepage distance		14.50	mm
Clearance distance		14.50	mm

Specifications (Unless otherwise specified temperature is 25°C)

Parameters	Symbol	Condition	Min	Typ	Max	Units
Input voltage nominal	$V_{pn}$			1000		V
Input voltage measuring range	$V_p$		-1500		+1500	V
Input current nominal	$I_{pn}$			8		mA
Burden resistance	$R_b$	with $\pm 12V$ at $V_{pn} = \pm 1000V$	30		200	$\Omega$
		with $\pm 12V$ at $V_{pn} = \pm 1500V$	30		100	$\Omega$
		with $\pm 15V$ at $V_{pn} = \pm 1000V$	100		320	$\Omega$
		with $\pm 15V$ at $V_{pn} = \pm 1500V$	100		180	$\Omega$
Resistance of secondary winding	$R_s$			45		$\Omega$
Resistance of primary	$R_p$			124		k $\Omega$
Output offset current at $V_{pn} = 0$	$I_{off}$			$\pm 0.20$		mA
Output current at $V_{pn}$	$I_{out}$			25		mA
Turns ratio	K			3100:1000		
Supply voltage ( $\pm 5\%$ )	$V_s$		$\pm 12$		$\pm 15$	V
Current consumption	$I_c$	at $\pm 15 V$		$12 + I_{out}$		mA
Variation of $I_{off}$ wrt temperature	$I_{ot}$	-25 to 70 °C		$\leq 0.80$		mA
Linearity error	$\Sigma_L$			$< 0.2$		%
Accuracy at $V_{pn}$	$X_G$			$\pm 0.8$		%
Response time 90% of $V_{pn}$	$t_{ra}$			$< 40.0$		$\mu S$
Total primary power loss				8		W
Ambient operating temperature	$T_A$		-25		+70	°C
Ambient storage temperature	$T_s$		-40		+85	°C
Mass	m			80		g

Input Output Characteristics

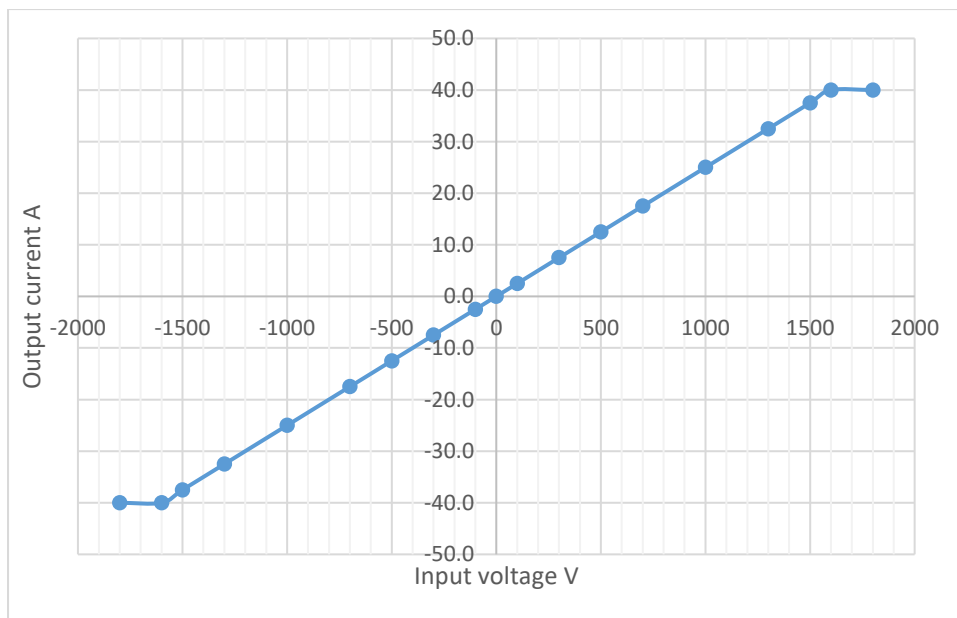

Mechanical dimensions

GENERAL TOL. ±1.0 mm	
ALL DIMENSIONS ARE IN 'mm'	SCALE -NTS

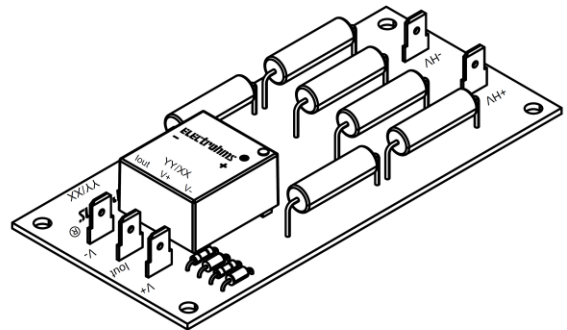
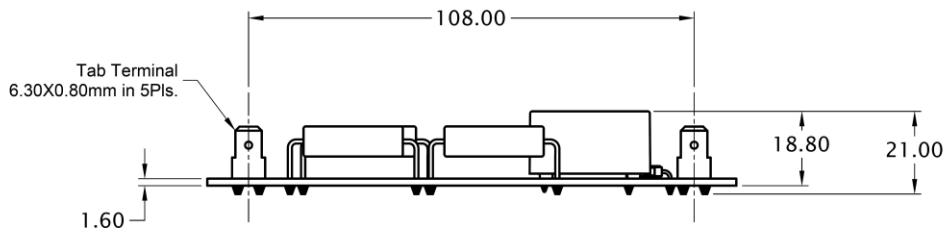
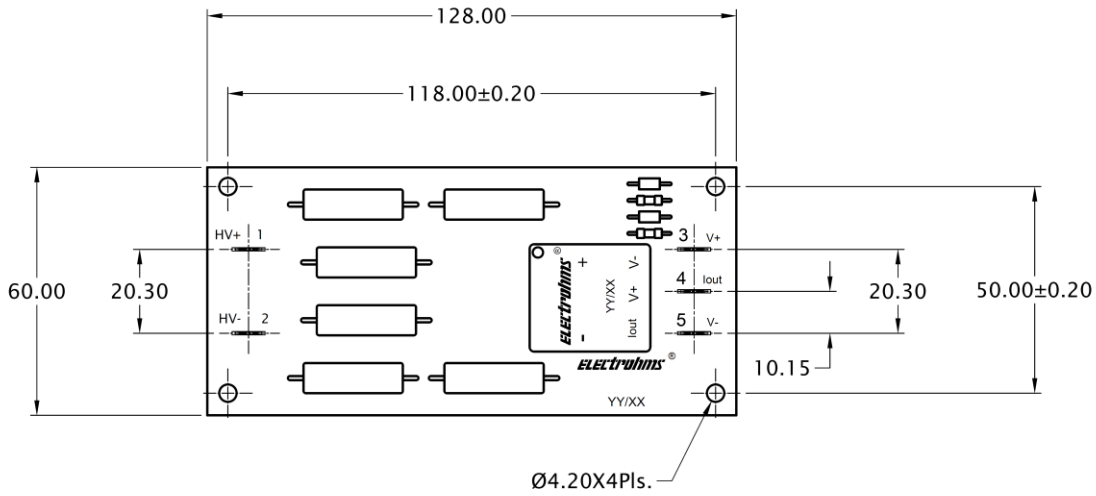

Connection Diagram

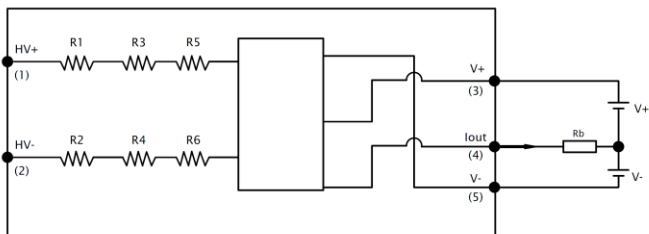

- Connector on the product: Faston tab, part no.- 62409-1, TE Connectivity AMP Connectors
- Suggested mating connector: Faston receptacle terminal part no.- 63609-2, TE Connectivity AMP Connectors
- Sensor mounting: 4 holes X Ø 4.2mm, M4 steel screws, recommended fastening torque 2.0 N-m
- $I_{out}$  is positive when  $V_p$  is applied to +HV terminal
- Power supply and output terminal is not protected against polarity reversal

### Safety



- This Current Transformer must be used in electric/electronic equipment with respect to applicable standards and safety requirements in accordance with the manufacturer's operating instructions.



- Caution, risk of electrical shock
- When operating the Sensor, certain parts of the module can carry hazardous voltage (eg. primary busbar, power supply).
- Ignoring this warning can lead to injury and/or cause serious damage.
- A protective housing or additional shield could be used.
- Disconnecting the main power must be possible
- Over voltage ( $\gg V_{PN}$ ) or missing of the power supply voltage can cause an additional remaining magnetic offset.
- This Sensors may only be used in electrical or electronic systems which fulfil the relevant regulations (Standards, EMC Requirements)
- Pay attention to protect non-isolated high-voltage current carrying parts against direct contact (e.g. with a protective housing)
- When installing the sensor, ensure that the safe separation (between primary circuit and secondary circuit) is maintained over the whole circuits and their connections.

### General information:

Electrohms reserves the right to make modifications on products for improvements without prior notice.