

 $I_{pn} = 200A \dots 1500A$ 

Representative image only

Features

- Isolated plastic case recognized according to UL 94-V0

Advantage

- Excellent accuracy
- Good linearity
- Low temperature drift
- Optimized response time
- Wide frequency bandwidth
- Current overload capability

Applications

- AC variable speed drives and servo motor drives
- Static converters for DC motor drives
- Battery supplied applications
- Uninterruptible power supplies (UPS)
- Switched mode power supplies (SMPS)
- Power suppliers for welding applications

Application domain

- Industrial

Standards

- UL508
- EN50178 (IEC 62477)

Insulation characteristics

Parameters	Symbol	Value	Units
Dielectric strength between primary and secondary terminals,50/60Hz, 60 seconds	V_d	4.9	kVrms
Comparative tracking index	CTI	600	V
Impulse withstand voltage 1.2/50 μ s	V_{im}	9.9	kVp
Insulation Resistance at 500 V DC	R_{IS}	>1000	M Ω
Creepage distance		11.0	mm
Clearance distance		11.0	mm
Working altitude (with pollution degree 2, Overvoltage category III)		4000 (max)	Metre above MSL

Product Range

Product Code	Primary Nominal Current (I_{pn})	Primary Measuring Range (I_p)
HSS200T01	200A	$\pm 600A$
HSS300T01	300A	$\pm 900A$
HSS400T01	400A	$\pm 1200A$
HSS500T01	500A	$\pm 1500A$
HSS600T01	600A	$\pm 1800A$
HSS700T01	700A	$\pm 2100A$
HSS800T01	800A	$\pm 2400A$
HSS900T01	900A	$\pm 2500A$
HSS1K0T01	1000A	$\pm 2500A$
HSS1K1T01	1100A	$\pm 2500A$
HSS1K2T01	1200A	$\pm 2500A$
HSS1K3T01	1300A	$\pm 2500A$
HSS1K4T01	1400A	$\pm 2500A$
HSS1K5T01	1500A	$\pm 2500A$

Specifications (Unless otherwise specified temperature is 25°C)

Parameters	Symbol	Condition	Min	Typ	Max	Units
Burden resistance	R_b			>10		k Ω
Output voltage	V_{out}	at $\pm I_{pn}$, $R_b = 10k\Omega$		± 4		V
Supply voltage ($\pm 5\%$)	V_s	operating at 12V reduces the measuring range		± 15		V
Current consumption at I_{pn}	I_c			± 15		mA
Output internal resistance	R_{out}			100		Ω
Overall accuracy) at I_{pn} (excluding offset)	X_G		-1		+1	%
Linearity error (excluding offset)	Σ_L		-1		+1	%
Output offset voltage	V_{off}		-20		+20	mV
Hysteresis offset voltage	V_{OH}	at $I_p = 0$ after a primary current of I_{pn}	-10		+10	mV
Temperature coefficient of V_{out}	TV_{OE}	-40 to +85°C	-0.1		+0.1	%/K
Reaction time at 90% of I_{pn}	τ_{ra}			<5		μs
Frequency bandwidth di/dt accurately followed	BW di/dt	-3dB, small signal bw	0		25	kHz A/ μs
Ambient operating temperature	T_A		-40		+105	°C
Ambient storage temperature	T_S		-50		+105	°C
Mass	m			230		g

Input & Output Characteristics

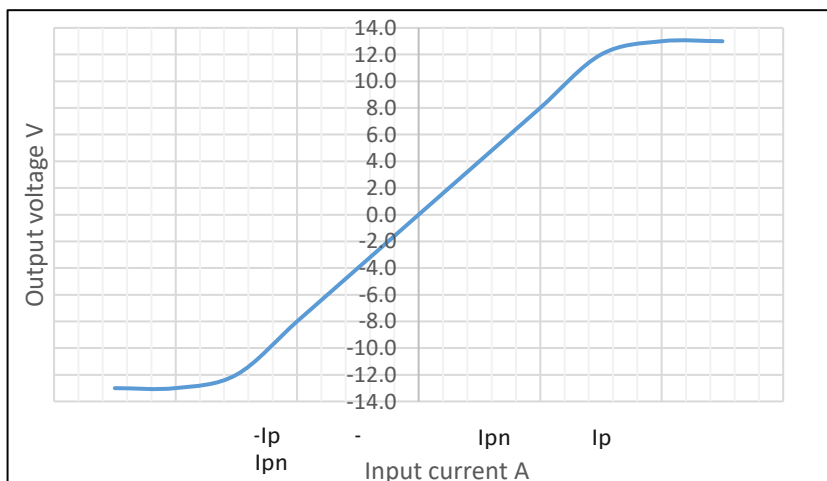

Mechanical dimensions

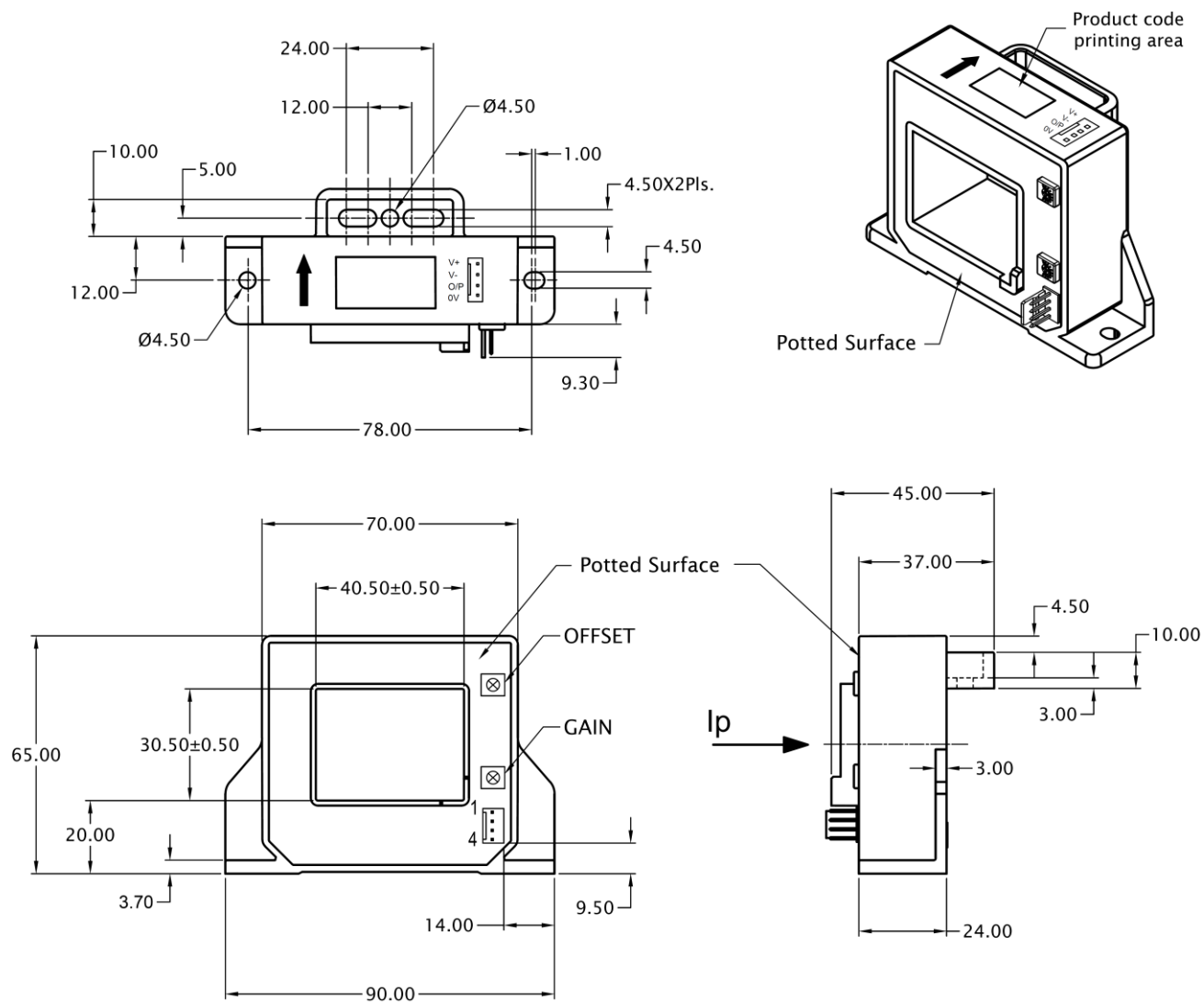

Tolerance unless otherwise specified

0.5 up to 3 in mm	> 3 up to 6 in mm	> 6 up to 30 in mm	> 30 up to 120 in mm	> 120 up to 315 in mm	> 315 up to 1000 in mm	ALL DIMENSIONS ARE IN 'mm'	
± 0.20	± 0.30	± 0.50	± 0.80	± 1.20	± 2.0	SCALE -NTS	

Connection Diagram

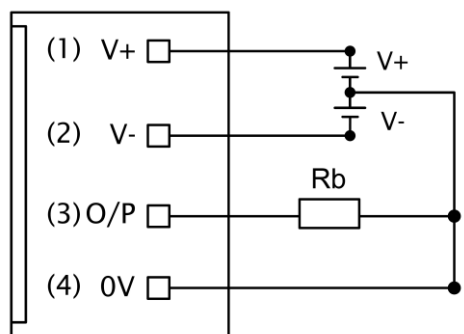

UL 508 certification and ratings

File number: E356273 Volume:1 section:2

Parameter	Unit	value
Primary potential involved	VAC/VDC	600
Ambient operating temperature	°C	80
Supply voltage	VDC	±15

1. This sensor shall be mounted in a suitable enclosure in end use
2. Sensor shall be used in pollution degree 2
3. The secondary terminals mating connector has not been evaluated for field wiring
4. Supply voltage for the sensor shall be provided through isolated voltage source

General information:

- Connector on the product: Connector header, part no-22-04-1041, Molex
- Suggested mating connector: Connector housing, part no-22-01-1042, & corresponding pin part no: 08-50-0114, Molex
- Sensor mounting: 2 holes X Ø 4.5mm, M4 steel screws, recommended fastening torque 3 N-m
- It is recommended to centrally locate the current carrying conductor or completely fill the central opening for optimum performance
- Output is positive when current (I_p) flows in the direction of arrow
- Ensure proper connection of Power supply to avoid damage to the Sensor
- Electrohms reserves the right to make modifications on products for improvements without prior notice.

Safety

- This Sensor must be used in electric/electronic equipment with respect to applicable standards and safety requirements in accordance with the manufacturer's operating instructions.



- Caution, risk of electrical shock
- When operating the Sensor, certain parts of the module can carry hazardous voltage (eg. primary busbar, power supply).
- Ignoring this warning can lead to injury and/or cause serious damage.
- A protective housing or additional shield could be used.
- Disconnecting the main power must be possible
- Over currents ($\gg I_{PN}$) can cause an additional voltage offset due to magnetic remanence.
- The temperature of the primary conductor shall not exceed 100 °C.
- This Sensors may only be used in electrical or electronic systems which fulfil the relevant regulations (Standards, EMC Requirements)
- Pay attention to protect non-isolated high-voltage current carrying parts against direct contact (e.g. with a protective housing)
- When installing the sensor, ensure that the safe separation (between primary circuit and secondary circuit) is maintained over the whole circuits and their connections.