

ELECTROHMMS

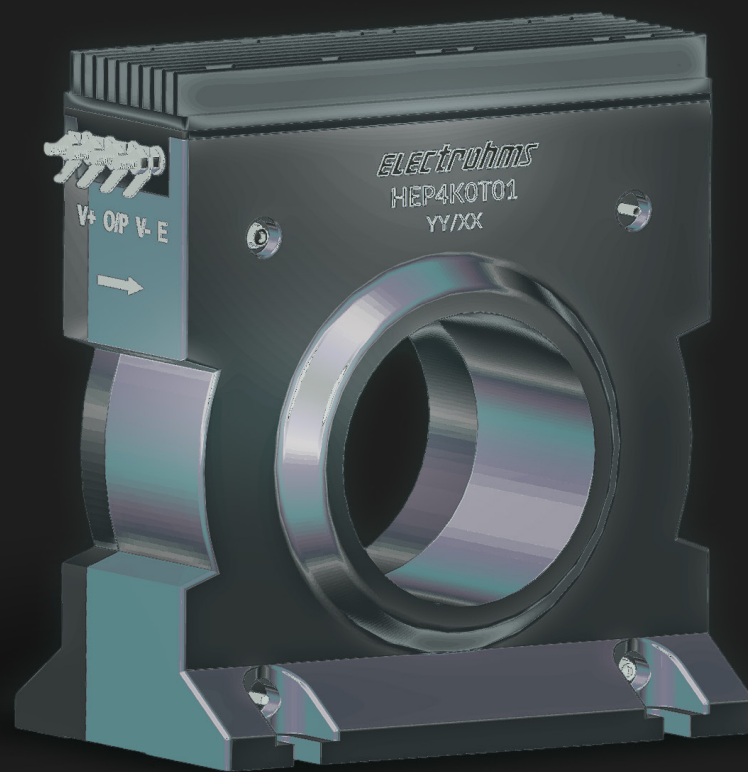

Product Catalogue

Current & Voltage Sensors

Current & Voltage Sensors

Table of Contents

Why Choose ElectroHms	4
Range Overview	5
Technology Selection Guide	7
Solutions	
Railways	8
Automotive & EV-Charging	10
Renewables	12
Industrial	14
IoT & Smart Monitoring	16
Product Index	
Closed-Loop Current Sensors	18
Open-Loop Current Sensors	20
Split-Core Current Sensors	21
Voltage Sensors	22
Current & Voltage Transformers	23
Technology Overview	26
General Notes & Safety	30

Electrohms is a leading designer & manufacturer of custom magnetics and sensors for measuring current and voltage.

With a wide range of standard components and proven custom design capability, we deliver on innovation, quality and service to our customers worldwide. We have over 50 years of experience in serving our customers in critical applications for railway, industrial, renewable energy, automation and IoT.

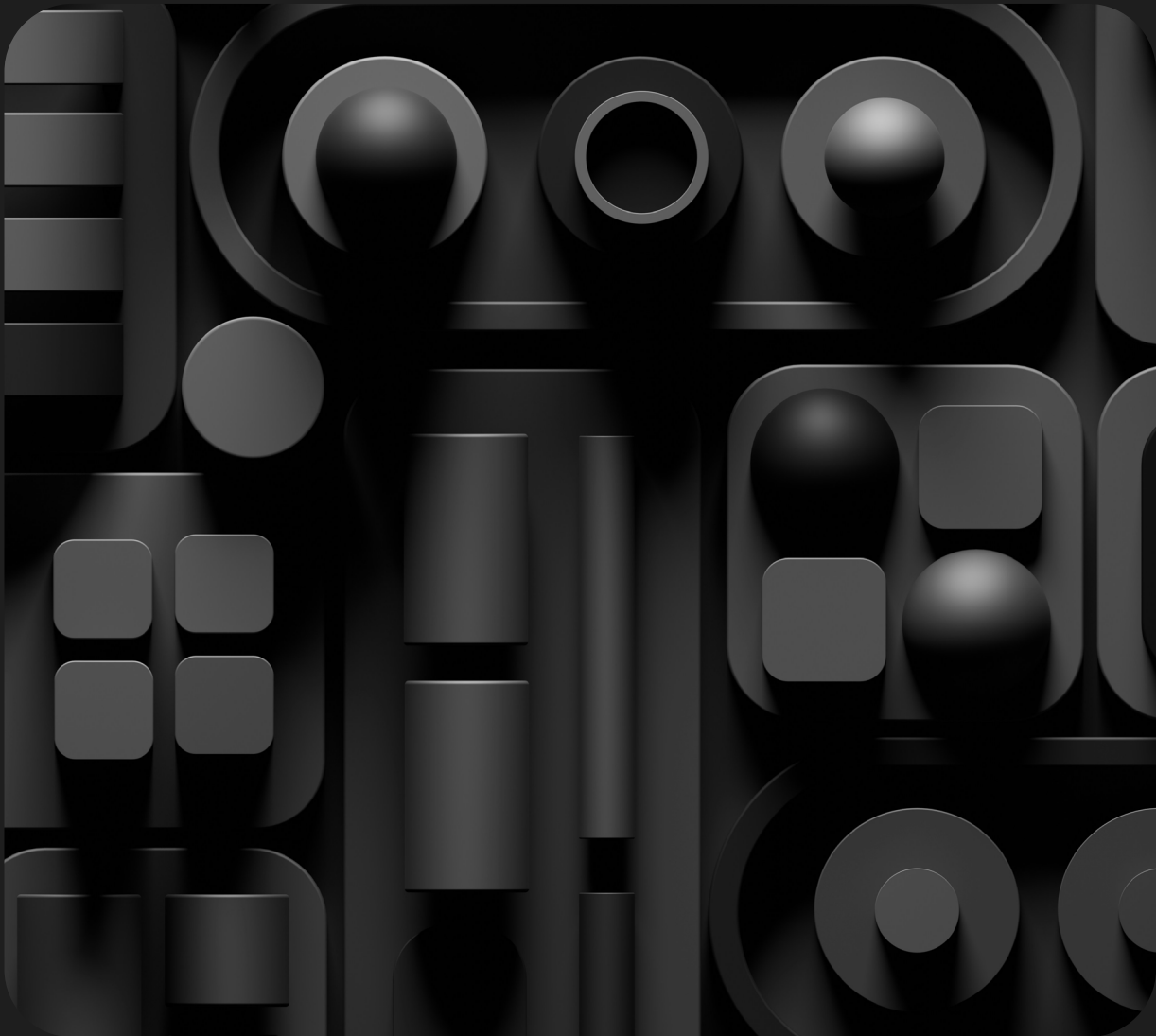

Why Choose Electrohms



Designer's Choice

We are a one stop shop for AC/DC measurement of current and voltage as well as custom magnetics. Our wide range of standard products makes it easy for designers to create high performance and cost-effective solutions.

Product Reliability

Reliability starts from a robust design and engineering process. We follow DFMEA and APQP processes and ensure delivery of highly reliable products. All product families undergo a full cycle of qualification testing which include extreme temperature cycling, dry and damp heat tests, vibration and EMI. We offer our customers qualification data on demand. We work with top quality supplier and buy electronic components only from reputed brands and proven traceability. All sensors are 100% tested on automated testing setups.

Agile Customisation

We are willing to go the extra mile to deliver a customized product where required to create outstanding end system performance. Using smart design tools and rapid prototyping our engineers deliver your prototypes and final samples on time.

Certifications & Standards

We are ISO 9001: 2015 certified and all our products are CE marked and meet ROHS 2 requirements. We use UL certified materials. We will get specific products UL-certified based on customer demand. We design and test our products to comply to the following standards:

- **EN50178:** Requirements for electronic equipment for use in power installation
- **EN50155:** Railway Applications – Electronic equipment used on rolling stock
- **CE certification:** As per EMC directive of EU
- **UL 508:** UL Certified
- **IEC 61010-1:** Safety requirements for electrical equipment for measurement, control, & laboratory use
- **IEC-Ex / ATEX:** Hazardous area compliance options available for explosive and challenging environments.



Range Overview

A practical portfolio for current & voltage measurement, control metering, and protection applications.

Product Family	Nominal Range	Best-Fit Applications
Closed-Loop Hall Current Sensors	25 A to 3000 A	High accuracy, fast response, low temperature drift and wide bandwidth for traction, drives, UPS and EV fast charging.
Open-Loop Hall Current Sensors	50 A to 2500 A	Compact and cost-effective current measurement for high-current control, protection and motor applications.
Split-Core Hall Current Sensors	50 A to 1500 A	Retrofit-friendly non-intrusive sensing for panels, battery systems, monitoring and industrial installations.
Voltage Sensors & Transducers	150 V to 4200 V	Galvanically isolated DC/AC voltage measurement for converters, chargers, inverters and railway systems.
AC current sensors / CTs	1 A to 1500 A	Metering, protection and control transformers for energy measurement, smart monitoring and relay inputs.

Hall Effect Current Sensors — Closed-Loop

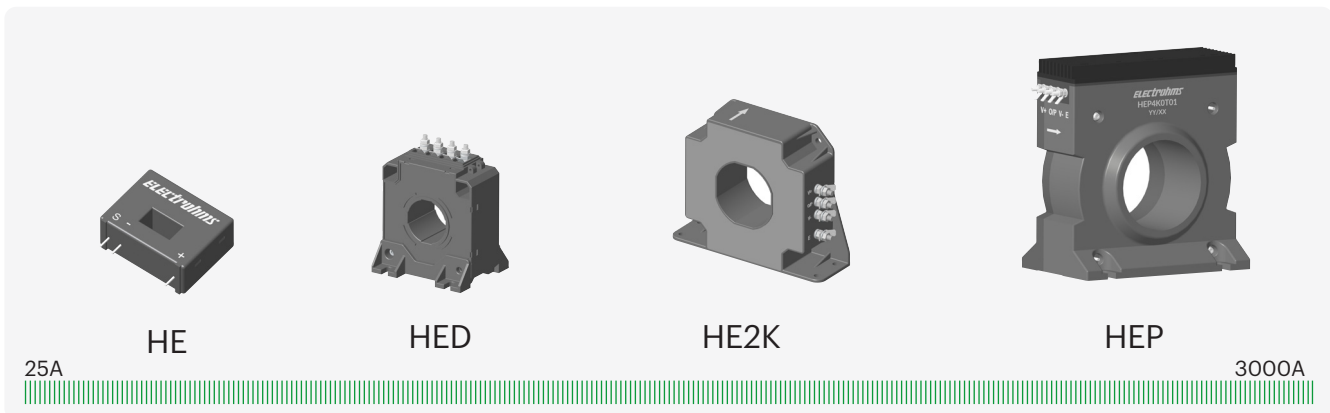

Hall Effect Current Sensors — Open Loop

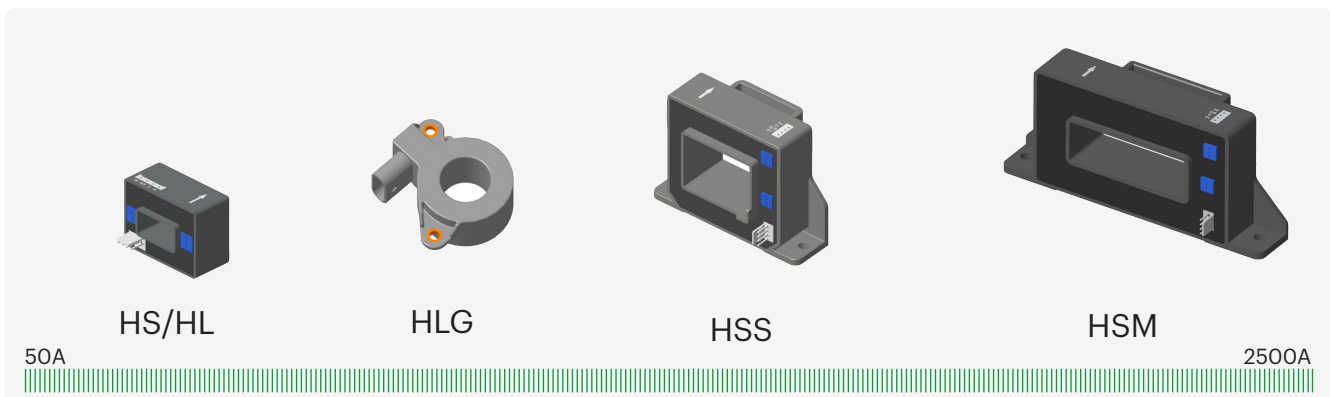

Range Overview

Hall Effect Current Sensors — Split-Core



Voltage Sensors

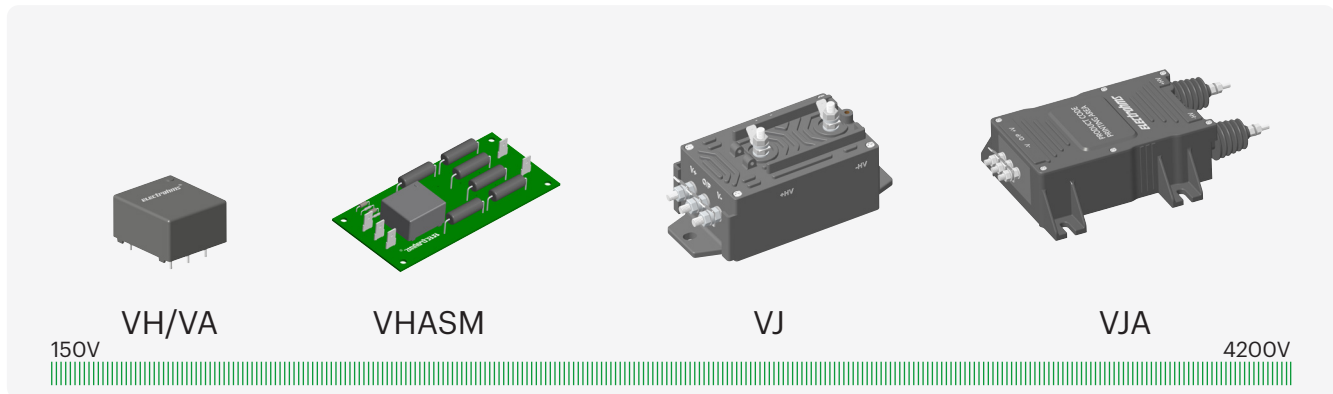

AC Current Sensors



Technology Selection Guide

Technology	Core Operating Strengths	Typical Applications
Closed-Loop Hall Effect	Premium accuracy, minimal offset drift, excellent linearity, high bandwidth, and rapid dynamic response.	Traction inverters, industrial drives, high-power UPS systems, wind converters, and DC fast charging stations.
Open-Loop Hall Effect	Compact physical footprint, low power consumption, and highly cost-effective across high-current paths.	Low-voltage motor control, light electric vehicles (2/3 wheelers), automotive auxiliary systems, and welding equipment.
Split-Core Hall Effect	Tool-free clamp-on installation for seamless DC/AC sensing without system downtime.	Retrofit energy monitoring, battery management racks, industrial panels, and cellular base station power tracking.
Current Transformers (CTs)	Self-powered AC metering, excellent galvanic isolation, simple system integration, and long-term stability.	Smart energy meters, distribution switchgear protective relays, commercial building sub-metering, and AC EV chargers.
Voltage Transducers	Robust galvanic isolation with high-linearity output proportional to primary AC/DC voltage levels.	Substation converters, solar/wind string inverters, EV charging infrastructure, and railway propulsion feedback.
Custom Magnetics & Assemblies	Tailored mechanical packaging, bespoke electrical scaling, integrated connectors, and application-specific standards compliance.	Customer-specific multi-channel sensor arrays, integrated busbars, smart shunt assemblies, and specialized fly-leads.

Critical Design Selection Parameters

When specifying a sensor for your design layout, prioritize the following system constraints:

Electrical Interface

Choose from standard current outputs, voltage outputs, standardized industrial loops (4-20 mA, 0-5 V, 0-10 V), or localized board-level connectivity via standard PCB pins, discrete connectors, or flexible fly-leads.

Mechanical Integration

Evaluate layout restrictions across PCB through-hole mounting, panel mounting, surface busbar clamping, and vertical/horizontal configurations relative to your primary conductor clearances.

Isolation & Safety

Match your design requirement against strict insulation coordination standards by analyzing required creepage and clearance distances, impulse withstand voltages, residual current device (RCD) constraints, and safety regulations.

Environmental Resilience

Ensure long-term reliability by choosing materials rated for your operating temperature envelopes, humidity profiles, continuous mechanical vibration/shock vectors, and high-frequency EMI exposures.



SOLUTIONS

Railways

Modern rail propulsion and auxiliary power conversion systems operate under punishing conditions: high-voltage dynamics, extreme magnetic noise, and severe mechanical shock. Electrohm's sensors deliver the rock-solid current and voltage feedback required for fail-safe control, efficiency optimization, and over-current protection across traction converters, auxiliary power units (APUs), electronic roof-mounted regulating units (ERRU), and signaling infrastructure.

Railway System Measurement Points

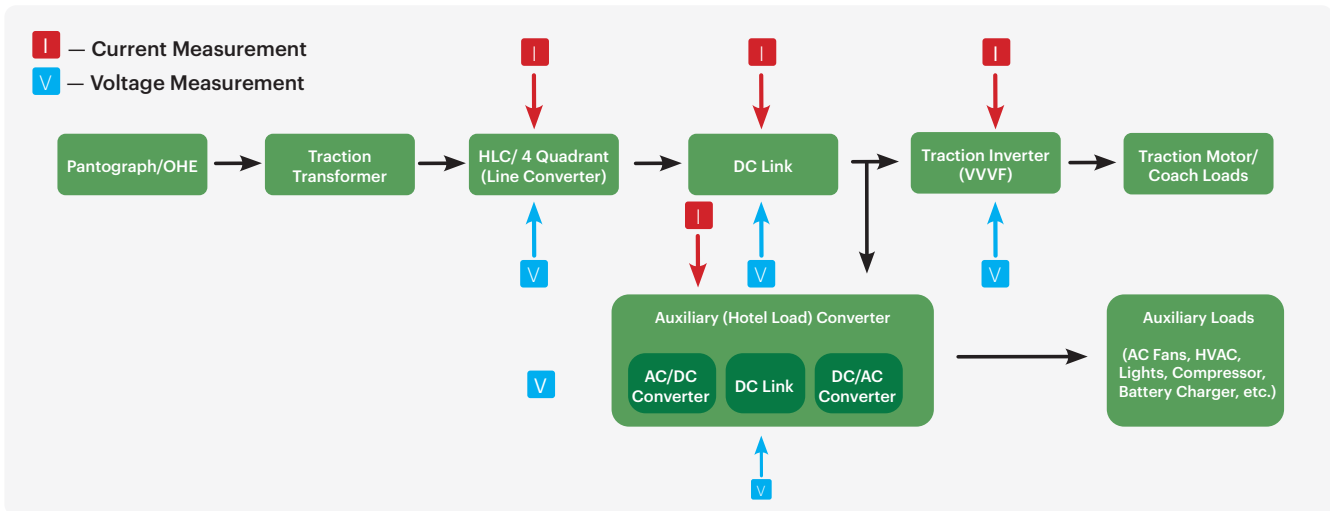

Applications

Traction Converters

High-bandwidth closed-loop current sensors and isolated voltage transducers provide accurate feedback for real-time motor control loops and efficient regenerative braking energy recovery.

Auxiliary Power Units & ERRU

Precision sensing for secondary subsystems including onboard HVAC, passenger coach lighting networks, onboard ventilation, and low-voltage battery charging circuits.

Trackside Infrastructure

AC current transformers and isolated DC sensors designed for trackside substations, asset health monitoring systems, and predictive maintenance.

Selection Matrix

Measurement	Recommended Product Families	Engineering Fitment Rationale
AC/DC Current	HE, HED, HER, HE2K, HEM (Closed-Loop Hall)	Measurement capabilities up to 2000 A rms. Delivers high-bandwidth, sub-microsecond response, and low thermal offset drift essential for precise inverter vector control.
DC-Link & AC Voltages	VJ, VJB, VJA (Voltage Transducers)	Delivers isolated voltage monitoring up to 4.2 kV and 18.5kV dielectric isolation with exceptional linearity and specialized connector options.
Auxiliary Power & Subsystem Infrastructure	HL, HS, HE Series	Designed to deliver precise control and fault monitoring for power supplies, battery chargers, and onboard passenger comfort loads.
Trackside Asset & Signaling Monitoring	Custom Current Transformers & Split-Core DC Sensors	Allows non-intrusive, clamp-on installation over existing cables or busbars, enabling reliable data-logging without track operational downtime.

Current Sensors



Voltage Sensors



Key Features

Electrical Ruggedness

High transient isolation voltage ratings, excellent common-mode rejection (CMR) against high-frequency switching noise (SiC/IGBT), and predictable fault-state responses.

Mechanical Durability

Fully encapsulated housings that resist moisture, dust, and continuous rail vibration. Available with integrated bus-bar locators and secure locking connectors.

Compliance Verification

Full design and test alignment with EN 50155 and EN 50178 railway standards. Type-test validation report summaries are available to Tier-1 rolling stock manufacturers on demand.



SOLUTIONS

Automotive

Leveraging our deeper expertise in high-reliability transit and industrial power electronics, Electrohm's delivers robust sensing solutions tailored for the high-volume, safety-critical automotive market. Our portfolio encompasses high-performance sensors engineered for xEV passenger car traction inverters, light electric vehicle controllers (2 and 3-wheelers), Battery Management Systems (BMS), On-Board Chargers (OBC), and localized charging infrastructure.

Automotive Ecosystem Measurement Points

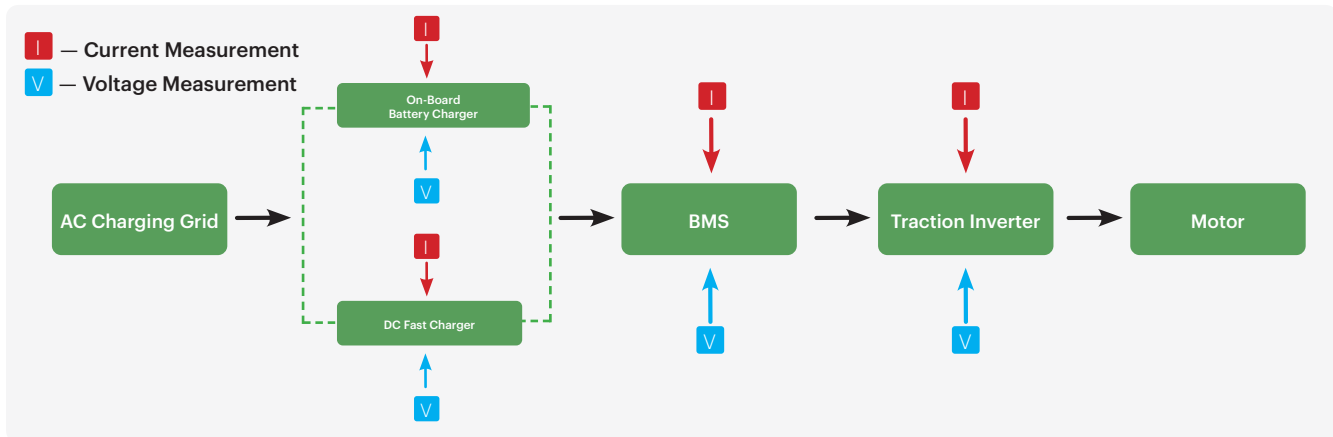

Applications

xEV Traction Inverters

High-accuracy, fast-response sensors for DC-link and phase-current measurement to optimize permanent magnet or induction motor control profiles.

Light Mobility Controllers

Cost-optimized, lightweight, high-volume open-loop sensors designed for compact 2-wheeler and 3-wheeler motor drives.

Advanced Battery Management (BMS)

Ultra-precise DC tracking for high-accuracy State of Charge (SOC) and State of Health (SOH) estimations, coupled with fast short-circuit safety intervention.

Charging Infrastructure (AC/DC)

Integrated solutions for compact AC wall boxes (including residual current leakage detection) and ultra-high-power DC fast charging stations requiring precise high-current/high-voltage feedback.

Selection Matrix

Measurement	Recommended Product Families	Engineering Fitment Rationale
Traction Inverter Phase/DC-Link	HL, HLB, HLU, HLG, HLH	High-current automotive-grade families with diverse mechanical variants (busbar, aperture, through-hole) tailored to compact packaging spaces.
2/3-Wheeler Motor Controllers	HLE, HLH	Extremely space-saving profiles with high cost-efficiency tailored to high-volume manufacturing lines.
High-Voltage Battery Pack (BMS)	GMR, Hall Effect, and Fluxgate DC Sensors	Comprehensive array for single- and three-phase chargers supporting energy metering and sensitive Type B residual current monitoring.
AC Charging Infrastructure / RCD	CT1316, FLA Leakage Sensors	Allows non-intrusive, clamp-on installation over existing cables or busbars, enabling reliable data-logging without track operational downtime.
DC Fast Charger Output Tracking	HEF, HE300, HE1K, VHASM, VJ Series	Handles continuous high DC current outputs and high voltage feedback, supporting dynamic charge sharing and fault diagnostics.

Current Sensors

							
HEAB500 200-500 A	HLE Series 200 A	HLB Series 200 A	HEF300 300 A	HEV Series 400 A	HEA Series 500-1000A	HLG050T02 50/320 A	FGB500T01 1500 A

Leakage Current & Residual Sensors

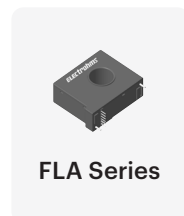

Voltage Sensors

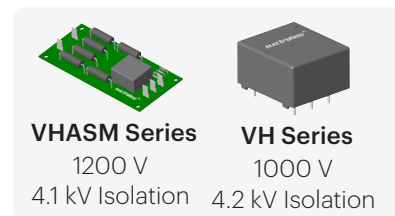

AC Current Transformers

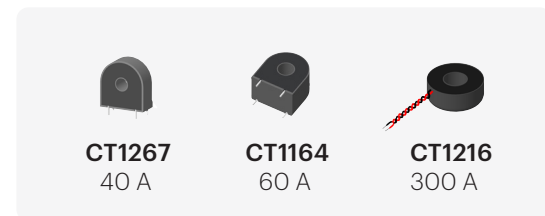

Key Features

Sensor Performance

Low temperature drift, minimal offset error, and high bandwidth response support reliable monitoring, protection, and control across BMS, OBC, DC-DC converters, and AC/DC charging systems.

Mounting & Connectivity

Compact, encapsulated designs with flexible mounting options and customised connectors enable easier integration into automotive and EV charging assemblies.

Compliance & Certification

Designed and tested for IEC 62752 requirements, with AEC-Q qualification support and type-test reports available on request.



SOLUTIONS

Renewables

As renewable systems scale, efficient power conversion and reliable fault detection become critical to performance and uptime. Electrohm's current and voltage sensors support solar inverters, wind converters and battery energy storage systems with accurate feedback for control, protection, grid synchronization and system monitoring.

Renewable Energy Inverter Measurement Points

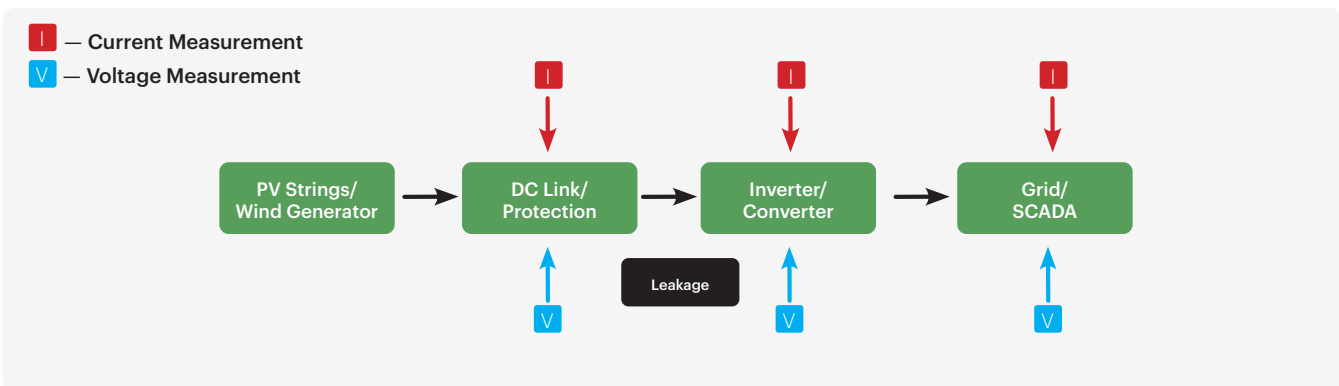

Applications

Central & String Inverters

Delivers fast, low-drift current feedback for high-power DC-to-AC conversion, grid-tie synchronization filters, and reactive power compensation loops.

Wind Power Converters

Ultra-reliable, high-capacity sensors designed to handle generator-side and grid-side inverter control loops under harsh thermal cycling and vibration.

BESS & Microgrids

Bi-directional DC current monitoring essential for safe battery state-of-charge (SOC) calculation, state-of-health (SOH) diagnostics, and catastrophic short-circuit protection.



Selection Matrix

Measurement	Recommended Product Families	Engineering Fitment Rationale
Inverter Input / Central DC-Link Current	HSS, HSM, HE, HE1K, HE2K	Supports continuous DC paths up to 2,500 A RMS. High-bandwidth performance ensures rapid overcurrent trip execution for IGBT/SiC protection.
High-Voltage DC & Grid Voltage Feedback	VHASM, VJ, VJA, VJB Series	Exceptionally space-saving layouts optimized for dense multi-string current measurements and integration with plant SCADA systems.
Leakage & Earth Fault Monitoring	FLA, customized AC leakage CT's	Highly sensitive residual current detection (RCD) to guarantee safety and compliance with international grid-tie fault protection standards.

Current Sensors

					
FLA Series 6mA- 3A	HSS Series 200-1500 A	HSM Series 500-2500 A	HE500 500 A	HE1K 1000 A	HE2K 2000 A

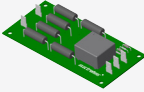
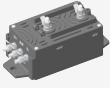
Voltage Sensors

			
VHASM Series 1200 V 4.1 kV Isolation	VJ2K 2000 V 7.5 kV Isolation	VJB Series 4200 V 12 kV Isolation	VJA Series 4200 V 18.5kV Isolation

Key Features

Solar Inverter Focus

Maximized efficiency via minimal internal power consumption, low offset voltage drift, high common-mode immunity against fast dv/dt transients, and ultra-compact physical profiles.

High-Power Converter Focus

Severe temperature cycling endurance, structural integrity against continuous mechanical wind loads, and certified insulation safety profiles.

Global Grid Standards

Fully compliant with CE and RoHS criteria, with comprehensive UL/cUL certification support to streamline your end-product approval process.



SOLUTIONS

Industrial

Industrial motor controllers, factory automation nodes, and backup power equipment require dependable, long-term feedback loops to control complex loads and safeguard heavy capital infrastructure. Electrohm provides a field-proven range of AC/DC sensors tailored for variable frequency drives (VFDs), industrial automation systems, uninterruptible power supplies (UPS), welding rectifiers, and factory energy management panels.

Industrial Drive, UPS, and Welding Measuring Points

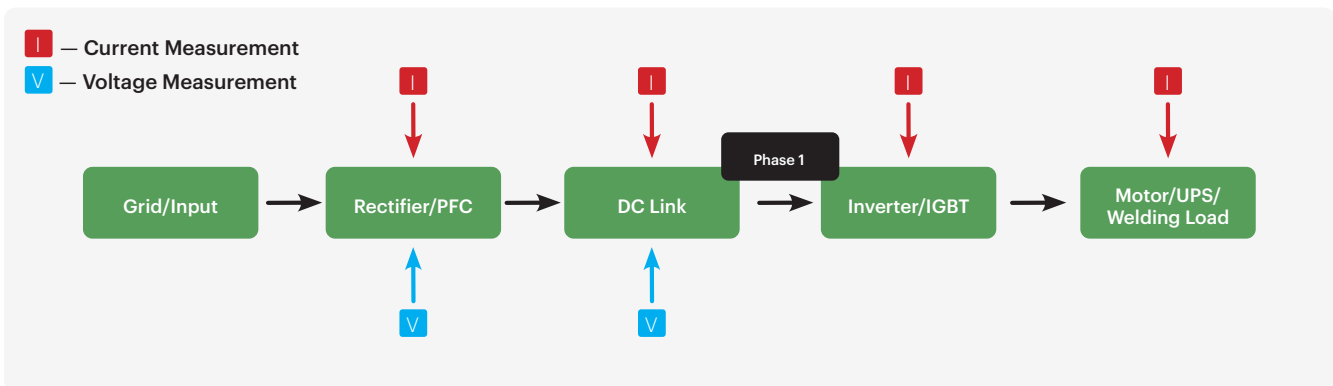

Applications

Variable Speed Drives (VFDs)

Dynamic phase-current measurement across automated systems, elevators, heavy conveyors, deep-well pumps, and electric process machinery

Inverters & Critical UPS Infrastructure

Continuous monitoring of battery charge/discharge cycles, dynamic output inverter regulation, and rapid power-stage fault mitigation.









Protection & Sub-Metering Systems

Solid-core and openable current transformers engineered for energy billing management, motor protection relays, and smart factory sub-metering.







Selection Matrix

Measurement	Recommended Product Families	Engineering Fitment Rationale
Phase Current	HL, HS, HE, HSS, HSM, HES, HEK	Full AC/DC capabilities up to 3,000 A RMS with wide frequency response to seamlessly track high-frequency PWM drive outputs.
DC-Link & Output Stage	Closed-Loop Hall Sensors & High-Isolation Voltage Transducers	High-speed feedback protects power switches (IGBTs/MOSFETs) while tracking charging cycles and output voltage stability.
Plant Sub-Metering & Relay Inputs	CT, ST, and Split-Core CT Series	Self-powered Class 1 accuracy transformers optimized for energy management and protective relay interfaces.
IGBT Welding Rectifiers	Closed-Loop Hall Effect Current Sensors	Delivers fast response times and low noise under high magnetic field environments, ensuring clean PWM loop control.

AC/DC Current Sensors (Low & Medium Voltage)

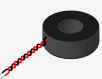
							
HL Series 15 A	HS Series 50 A	HE055 50 A	HSS Series 200 A	HE300 300 A	HSM Series 500 A	HE500 500 A	HE1K 1000 A

AC Current Transformers

							
CT1248 10 A	CT1267 40 A	CT1164 60 A	CT1216 300 A	CT1392 300 A	ST1370 300 A	ST1383 300 A	ST1409 300 A

Key Features

High-Speed Control Loops

High frequency bandwidth, minimal response delay times, exceptional linearity across the full dynamic range, and predictable overcurrent behaviors.

Retrofit & Service Simplicity

Dedicated split-core geometries and robust panel-mount packages allow quick on-site field installation without altering active wiring layouts.

Flexible Output Configurations

Match your system controller using traditional current output signals, standardized voltage outputs, or 4-20 mA current loops.

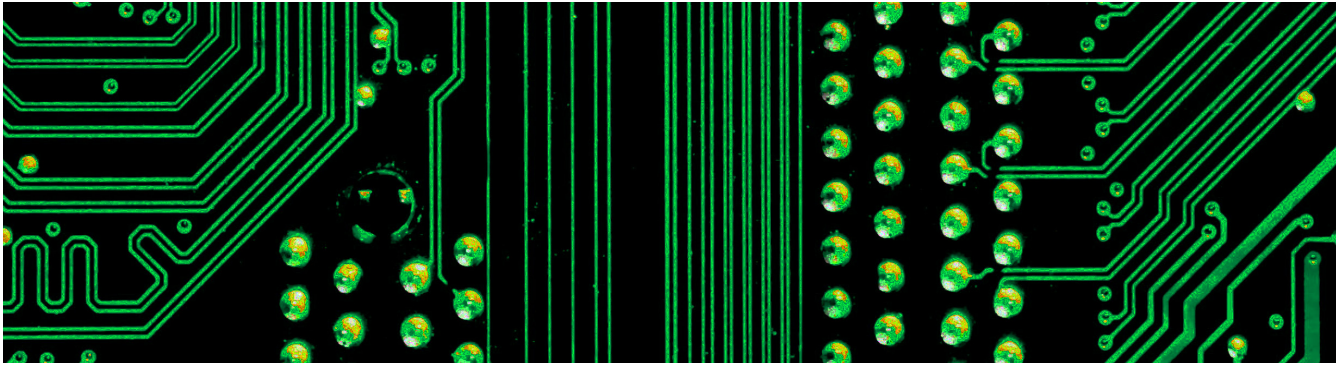

SOLUTIONS

IoT & Smart Monitoring

The digital transformation of energy infrastructure requires pervasive, granular circuit monitoring across existing factories, data centers, and grid assets. Electrohm's IoT and Smart Monitoring solutions provide the sensing layer needed to feed cloud platforms, PLC nodes, and edge computing gateways with highly accurate real-time data without interrupting continuous operations.

Smart Monitoring and Metering Architecture

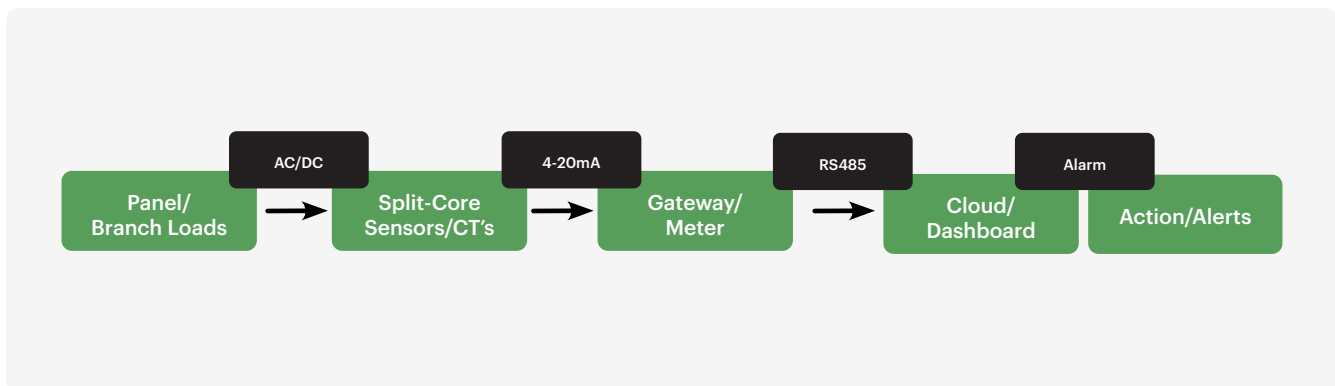

Applications

DC Branch & Battery Rack Monitoring

Galvanically isolated branch sensing to monitor DC energy storage arrays, telecom power backup rooms, and data center busways.

AC Energy Management & Commercial Metering

Solid-core and openable current transformers tailored for facility power sub-metering, power quality analysis, and load balancing.

Smart Factory Retrofitting

Clamp-on options designed for lightning-fast deployment over legacy wiring with zero production interruption or system wiring rework.

Selection Matrix

Measurement	Recommended Product Families	Engineering Fitment Rationale
DC Branch & Battery Strings	HJB, HL, HJ Split-Core DC Series	Provides absolute galvanic isolation, custom output scaling options, and compact aperture paths tailored to tight rack layouts.
AC Multi-Load Branch Metering	ST1409, ST1361, ST1370, & CT Families	Solid-core and split-core transformers offering Class 1 precision, delivering highly accurate load profile diagnostics.
Legacy Plant Retrofit Installations	Split-Core Hall Sensors & Split-Core CTs	Toolless, clamp-on design allows fast field service installation with zero machine down-time.
IoT Edge Gateway Interface	Sensors with 4-20 mA, 0-5 V, or 0-10 V Conditioned Outputs	Eliminates the need for external analog signal conversion; outputs link directly into standard PLCs and IoT transmitter modules.

DC Current Sensors



HJB Series
1500 A



HL Series
600 A



HJ Series
1000A

AC Split-Core Transformers



ST1409
50- 300 A



ST1370
100-1000A

Key Features

Installation Blueprint

Prioritizes openable clamp split-cores, ultra-compact physical footprints, robust reverse-polarity protection, and built-in protection against field miswiring.

Data Integrity Focus







Delivers stable output baselines, excellent linearity, low thermal offset drift, and seamless software integration parameters.

Custom IoT Capability

Specialized signal conditioning circuits and localized firmware options can be designed to directly convert native analog sensor signals into IP-compatible digital data streams.

PRODUCTS







Closed-Loop Current Sensors

Series	Family	Nominal current (A)	Output	Supply Voltage (V)	Output Termination	Primary Conductor Opening (mm)	Standard
HA 	HA025T01	25	+2.5 ±0.625V	+5.0	Pins	13x7.15	EN50178
	HE055T01	50	50mA	±12 - ±15	Pins	13x7.15	EN50178, UL 508
HE  	HE100T01	100	50mA	±12 - ±15	Pins	13x7.15	EN50178
	HEF300T03	300	120mA	±24	Connector header, B3P-VH(LF)(SN), JST Mfg. Co. Ltd.	Φ25	EN50178
	HEJ300T04-CB03	300	150mA	±20	Connector header, Micro-Fit+ 206832, Molex	10 x 20.10	EN50178, UL508*
	HE050...300T04	50-300	25...150mA	±12 - ±15	Faston Tab 6.3 x 0.8mm	Φ25	EN50178
HE500 	HE500T02-CB00	500	100mA	±15 - ±24	Connector header, Molex	Φ31.80	EN50178
	HE500T05-CB00	500	100mA	±15 - ±24	JST B3P-VH series 3 pin header	Φ31.80	EN50178
	HE500T07	500	100mA	±15 - ±24	Molex Minifit Jr 5566 series	Φ31.80	EN50178
	HE500T08	500	142.8mA	±15 - ±24	Flylead	Φ30.20	EN50178
	HE500T21-CB01	500	125mA	±15 - ±24	Mini-Fit Jr 5566, Molex	Φ31.80	EN50178
HE1K 	HE1K0T04-CB00	1000	200mA	±15 - ±24	Mini-Fit Jr 5566, Molex	Φ40.50	EN50178
	HE1K0T05-CB00	1000	200mA	±15 - ±24	BHP-VH-1(LF)(SN), JST Mfg. Co. Ltd.	Φ40.50	EN50178
	HE1K0T21-CB00	1000	200mA	±15 - ±24	Mini-Fit Jr 5566, Molex	Φ40.50	EN50178
HE2K 	HE2K0T01-CB10	2000	400mA	±15 - ±24	Screw studs	Φ60.5	EN50178
	HE2K0T02-CB00	2000	400mA	±15 - ±24	Block header, Phoenix Contact	Φ60.5	EN50178
	HE2K0T02-CB10	2000	500mA	±15 - ±24	Phoenix contact header, MCV series 3 pin	Φ60.5	EN50178
	HE2K0T03	2000	500mA	±15 - ±24	M5 screw studs, side termination	Φ60.5	EN50178
	HE2K0T03-CB00	2000	500mA	±15 - ±24	M5 studs & Faston tab, TE Connectivity AMP connectors	Φ60.5	EN50178
	HE2K0T04	2000	400mA	±15 - ±24	M5 screw studs, side termination	Φ60.5	EN50178
	HE2K0T04-CB00	2000	400mA	±15 - ±24	B3P-VH(LF)(SN), JST Mfg. Co. Ltd.	Φ60.5	EN50178
HEA 	HEA1K0T06-CB02	1188	395mA	±24	Block header, Phoenix Contact	Φ43	EN50178, UL508*
	HEA1K0T05-CB00	1000	200mA	±15 - ±24	Connector header, part no. BHP-VH-1(LF)(SN), JST Mfg. Co. Ltd.	Φ43	EN50178, UL508*
	HEA1K0T07-CB00	1000	200mA	±12 - ±24	D-SUB Connector 9-Pin, row female with screw lock UNC 4-40	Φ42.50	EN50178, UL508*
	HEA1K0T12-CB00	1000	200mA	±15 - ±24	Connector header, Mini-Fit Jr 5566, Molex	Φ43	EN50178, UL508, EN50155

All products are CE, RoHS, and REACH compliant. UL508* : UL certification is under process

PRODUCTS









Closed-Loop Current Sensors

Series	Family	Nominal current (A)	Output	Supply Voltage (V)	Output Termination	Primary Conductor Opening (mm)	Standard	
HEAB 	HEAB500T01	500	143mA	15 - ±24	M4 Studs	Φ32	EN50178, EN50155	
	HEAB500T10	500	143mA	15 - ±24	SMS6GE6 Burndy connector	Φ32	EN50178, EN50155	
HED 	HED500T01	500	100mA	±15 - ±24	M5 screw studs	Φ42.0	EN50178, EN50155	
	HED1K0T01	1000	200mA	±15 - ±24	M5 screw studs	Φ42.0	EN50178, EN50155	
	HED1K0T01-CB11	1000	250mA	15 - ±24	M5 screw studs	Φ42.0	EN50178, EN50155	
	HED1K3T01	1300	325mA	15 - ±24	M5 screw studs	Φ42.0	EN50178, EN50155	
	HED1K0T02	1000	200mA	15 - ±24	M5 screw studs	Φ42.0	EN50178, EN50155	
	HED1K0T02-CB11	1000	250mA	15 - ±24	M5 screw studs	Φ42.0	EN50178, EN50155	
	HED1K0T04-CB12	1000	200mA	15 - ±24	SUB-D TRAC Gimota connector	Φ42.0	EN50178, EN50155	
	HED1K3T01-CB10	1300	325mA	15 - ±24	CPC 11 series, AMP	Φ42.0	EN50178, EN50155	
	HED1K3T01-CB11	1300	325mA	21 - ±24.1	M5 studs	Φ42.0	EN50178, EN50155	
	HED1K3T02	1300	325mA	15 - ±24	M5 studs & Faston tab, TE Connectivity AMP connectors	Φ42.0	EN50178, EN50155	
	HED1K3T02-CB11	1300	325mA	21 - ±24.1	M5 studs & Faston tab, TE Connectivity AMP connectors	Φ42.0	EN50178, EN50155	
	HEM 	HEM2K0T01-CB00	2000	400mA	15 - ±24	Connector header, TE Connectivity AMP Connectors	Φ63.50	EN50178, EN50155
		HER1K0T03	1000	200mA	15 - ±24	CPC 13 series, AMP	Φ42.0	EN50178, EN50155
HER 	HER1K3T01-CB10	1300	325mA	15 - ±24	CPC 11 series, AMP, side mounted	Φ42.0	EN50178, EN50155	
	HER1K3T02-CB10	1300	325mA	15 - ±24	M5 screw studs	Φ42.0	EN50178, EN50155	
HEV 	HEV400T01	400	133.33mA	±15	Flylead	13 x 30	EN50178, EN50155	
	HEV400T02	400	80mA	±15	Connector header, part no. 70543-000, Molex	13.50 x 30.50	EN50178, EN50155	
	HEV500T03-CB12	500	250mA	±15	Connector header, part no. 22-04-1041, Molex	13 x 30	EN50178, EN50155	
HEP 	HEP3K0T01	3000	600mA	±24	M5 screw studs	Φ102.0	EN50178	

All products are CE, RoHS, and REACH compliant. UL508* : UL certification is under process

PRODUCTS





Open-Loop Current Sensors

Series	Family	Nominal current (A)	Output	Supply Voltage (V)	Output Termination	Primary Conductor Opening (mm)	Standard
HLH 	HLH025T01	25	Voff $\pm 0.625V$	+5.0	PIN	$\Phi 5.7$	EN50178
HLG 	HLG050T02-DS	50, 320	Voff +2.0, Voff +1.664	+5.0	Connector housing, Part no. 1-1456426-5, TE connectivity	$\Phi 22.50$	ISO 26262
HL 	HL050...600T05-CB11	50-600	Voff +2.0	+5.0	Connector header, part no. 22-04-1041, Molex	20.4 x 10.40	EN50178
	HL050...600T05-CB10	50-600	Voff $\pm 0.625V$	+5.0	Connector header, part no. 22-04-1041, Molex	20.4 x 10.40	EN50178
HLE 	HLE200T01	200	Voff $\pm 1.0V$	+5.0	PIN	$\Phi 16$	ISO 26262
	HLE450T01	450	Voff $\pm 1.0V$	+5.0	PIN	$\Phi 16$	ISO 26262
HLB 	HLB200T01	200	Voff +2.0V	+5.0	Connector header, part no. 22-04-1041, Molex	$\Phi 12.50$	ISO 26262
	HLB600T01	600	Voff +2.0V	+5.0	Connector header, part no. 22-04-1041, Molex	$\Phi 12.50$	ISO 26262
	HLB800T01	800	Voff +2.0V	+5.0	Connector header, part no. 22-04-1041, Molex	$\Phi 12.50$	ISO 26262
HS 	HS050...600T01	50-600	4.0V	± 15.0	Panel Mountable	20.5 x 10	UL508*
	HS050...600T10	50-600	4.0V	± 15.0	Flylead wire 350mm	20.5 x 10	UL508*
HSS 	HSS200...1K5T01	200-1500	4.0V	± 15.0	Molex 5045 series, 4pin	40.5 x 30.5	UL508
HSM 	HSM500...2K5T01	500-2500	4.0V	± 15.0	Molex 5045 series, 4pin	64.0 x 21.0	UL508*
	HSM500...2K5T02	500-2500	4.0V	± 15.0	Connector header, Part no. 1881574, Phoenix Contact	64.0 x 21.0	EN50178, UL508*
FLA 	FLA1K0T01	1	Voff $\pm 2.0V$	+5.0	PCB Mountable	$\Phi 12.60$	IEC62752
	FLA300T01-LK	6mA DC / 30mA AC	Digital output	+5.0	PCB Mountable	$\Phi 12.60$	IEC62752
	FLA3E3T01	3	Voff $\pm 0.625V$	+5.0	PCB Mountable	$\Phi 12.60$	IEC62752

All products are CE, RoHS, and REACH compliant. UL508* : UL certification is under process

PRODUCTS



Split-Core Current Sensors

Series	Family	Nominal current (A)	Output	Supply Voltage (V)	Output Termination	Primary Conductor Opening (mm)	Mounting	Standard
HJ 	HJ050...500T09	50-500	+2.5 ±1V	+5.0	Phoenix contact header, BCH350V series 4pin	Φ20	Flange	EN50178
	HJ050...200T02	50-200	+2.5 ±1V	+5.0	Molex 5045 series, 4pin	Φ20	Flange	EN50178
	HJ300...500T02-CB10	200-500	+2.5 ±1V	+5.0	Molex 5045 series, 4pin	Φ20	Flange	EN50178
	HJ100...1K0T08-CS1	100...1000	4-20mA	12	Connector header, part no. 175752, Phoenix Contact	Φ40.5	Flange	EN50178
HK 	HK050...500T03	50-500	4.0V	±12 - ±15	Molex 5045 series, 4pin	Φ20	Flange	EN50178
	HK050...500T09	50-500	4.0V	±12 - ±15	Phoenix contact header, BCH350V series 4pin	Φ20	Flange	EN50178
	HK100...2K0T04	100-2000	4.0V	±15.0	Phoenix contact header, BCH350V series 4pin	Φ40.5	Flange	EN50178
HJB 	HJB1K5T01	1500A	2.5±1.5V	9.0-18.0	Connector header, part no. 175752, Phoenix Contact	Φ50	Mounting flange available on request	EN50178
	HJB-1K0...1K5T01-CS1	1000...1500A	4-20mA	+24V	Connector header, part no. 175752, Phoenix Contact	Φ50	Mounting flange available on request	EN50178
HJB (ATEX) 	HJB1K5T01-CS1	1500A	4-20mA	+24V	Connector header, part no. 175752, Phoenix Contact	Φ50	Mounting flange available on request	IEC 60079-11, IEC 60079-0, ISO 80079-34
HJ (ATEX) 	HJ050...1K0T08-CS2	50...1000	4-20mA	+24V	Connector header, Phoenix Contact	Φ40.5	Flange	IEC 60079-11, IEC 60079-0, ISO 80079-34

All products are CE, RoHS, and REACH compliant. UL508* : UL certification is under process

PRODUCTS

Voltage Sensors

Series	Family	Input (Vrms)	Output	Supply Voltage (V)	Isolation Voltage (kV)	Mounting	Standard
VH 	VH1K0T01	1000V	25mA	±15V	4.2	PCB	EN50178
	VHASM150T01	150V	25mA	±15V	4.2	Flange	EN50178
VHASM 	VHASM600T01	600V	25mA	±15V	4.2	Flange	EN50178
	VHASM750T02	750V	20mA	±15V	4.2	Flange	EN50178
	VHASM1K0T01	1000V	25mA	±15V	4.2	Flange	EN50178
	VHASM1K2T02	1200V	20mA	±15V	4.2	Flange	EN50178
	VJ 	VJ250T03-CB00	250V	50mA	±15V - ±24V	7.5	Flange
	VJ500T03-CB00	500V	50mA	±15V - ±24V	7.5	Flange	UL508, EN50178, EN50155
	VJ750T03-CB00	750V	50mA	±15V - ±24V	7.5	Flange	UL508, EN50178, EN50155
	VJ1K0T03-CB00	1000V	50mA	±15V - ±24V	7.5	Flange	UL508, EN50178, EN50155
	VJ1K5T03-CB00	1500V	50mA	±15V - ±24V	7.5	Flange	UL508, EN50178, EN50155
	VJ2K0T03-CB00	2000V	50mA	±15V - ±24V	7.5	Flange	UL508, EN50178, EN50155
VJA 	VJA4K2T01	4200V	50mA	±15V - ±24V	18.5	Flange	EN50178, EN50155
VJB 	VJB4K2T01	4200V	50mA	±15V - ±24V	12	Flange	EN50178, EN50155

All products are CE, RoHS, and REACH compliant. UL508* : UL certification is under process

PRODUCTS

Current & Voltage Transformers

Energy Metering

Product SKU	Primary Current	Turns Ratio	Burden Resistance	DC Resistance	Amplitude Error	PE (Deg)	Secondary Termination
CT1264-RC	0.01 – 5	1:500	85	62-75	0.1	0.20	Fly Lead
CT1265-RC	0.02 – 1	1:500	85	62-75	0.1	0.20	Fly Lead
CT1248-A2-RC	0.05 – 10	1:1500	75	45 – 60	0.2	0.50	PCB
CT1248-A1-RC	0.25 – 20	1:2500	90	120-145	0.5	0.50	PCB
CT1176-RC	0.25 – 20	1:2500	90	98 – 120	0.5	0.50	PCB
CT1231-A1	0.25 – 30	1:2500	30	132 – 168	0.3	1	PCB
CT1232-A1	0.25 – 30	1:2500	30	132 – 168	0.3	1	Fly Lead
CT1267-A1-RC	0.25 – 40	1:2500	30	86 – 105	0.1	0.25	PCB
CT-1316	0.25 – 40	1:2500	100	108 – 138	0.1	0.25	PCB
CT1164-A1-RC	0.25 – 60	1:2500	37.50	62-75	0.1	0.20	PCB
CT1295-RC	0.25 – 60	1:2500	37.5	62-75	0.1	0.20	Fly Lead
CT1365-RC	0.25 – 60	1:1000	8.50	11.5 – 14.1	0.1	0.20	PCB
CT1273-A1-RC	1 – 100	1:2500	7.50	37 – 47	0.1	0.20	PCB
CT1275-A1-RC	1 – 100	1:2500	7.50	37 – 47	0.1	0.20	Fly Lead
CT1332-A1-RC	1 – 120	1:2500	6.25	85 – 105	0.7	3.50	PCB
CT1216A1-RC	1 – 300	1:2500	6.80	21	0.1	0.10	Fly Lead

PRODUCTS

Current & Voltage Transformers

Protection & Control

Product SKU	Primary Current	Turns Ratio	Burden Resistance	DC Resistance	Amplitude Error	PE (Deg)	Secondary Termination
CT1202-RC	40	1:1000	100	36 – 46			Fly Lead
CT1270	0.05 – 5	1:700	10	28	1.5		PCB
CT1278	5 – 60	1:4000	390	219 – 279	<3		PCB
CT1337-RC	0.03 – 0.30	1:700	100	16			PCB
CT1292-B1	1 – 100	1:1800	25	46	<1.5	<1	Fly Lead
CT1363	5 – 60	1:4000	390	239 – 305	3		PCB
CT1321	0.25 – 2	1:1000	500	34 – 42			PCB
CT1333	5 – 120	1:4000	300	162 – 198	3		PCB

AC Split-Core Current Transformers

Product SKU	Primary Current	Operating temperature	Internal Diameter	Output Signal	Amplitude Error	Secondary Termination
ST1361-V33310...80	5 – 80	-10° – +70°C	9 mm	0 – 0.333V	≤ 1.0	Fly Lead
ST1409-V333050...300	50 – 300	-10° – +70°C	20 mm	0 – 0.333V	≤ 1.0	Fly Lead
ST1370-V33100...1000	100 – 1000	-10° – +70°C	40 mm	0 – 0.333V	≤ 1.0	Fly Lead
ST1383-V33100...1K5	500 – 1500	-10° – +70°C	50 mm	0 – 0.333V	≤ 1.0	Fly Lead
ST1353-C2005...80	50 – 80	-10° – +70°C	10 mm	4 – 20 mA	≤ 2.0	Connector

PRODUCTS

Current & Voltage Transformers

Voltage Measurement & Isolation Transformers

Product SKU	Nominal Input	Output at V_{pn}	Burden Resistance (Ω)	Turns Ratio	Dielectric Strength	Operating Temperature	Secondary Termination	Mounting Type
VT1090	110 V _{rms}	4.3 V	2000	1:1	4.0 kV AC	-10° — 60°C	Pin Terminals	PCB
VT1329	110 V _{rms}	1:700	3300	47:1	4.0 kV AC	-10° — 60°C	-10° — 60°C	PCB
VT1342	400 V _{rms}	1:4000	3300	174:1	4.0 kV AC	-10° — 60°C	-10° — 60°C	PCB

Product SKU	Frequency	Inductance	DC Resistance	Turns Ratio	Dielectric Strength	Operating Temperature	Secondary Termination	Mounting Type
VT1211-RC	50/60 Hz	18 H	135-165	1:1	2.5 kV AC	-10° — 60°C	Pin Terminals	PCB

TECHNOLOGY

Closed Loop Hall-Effect Technology

Compared to the open loop sensors, closed-loop current sensors have a compensation winding on the core that dramatically improves performance. The closed loop transducers use the Hall generator voltage to create a compensation current in a the secondary coil to create a magnetic flux which is equal to and in the opposite direction of flux generated by the input current as measured by the Hall generator. In other words, the secondary current, I_{out} , creates a flux equal in amplitude, but opposite in direction, to the flux created by the primary current and thus the total flux in the core gap is always being nulled to zero.

Operating the Hall generator in a zero flux condition eliminates the drift of gain with temperature. An additional advantage to this configuration is that the secondary winding will act as a current transformer at higher frequencies, significantly extending the bandwidth and reducing the response time of the transducer. When the magnetic flux is fully compensated zero, the magnetic potential ampereturns of the two coils are identical. Hence: $NP \cdot IP = NS \cdot IS$ which can also be written as $IS = IP \cdot NP / NS$. Consequently, the secondary current, I_{out} , is the exact image of the primary current, IP , being measured. Inserting a "burden resistor", R_b , in series with the secondary coil see fig. creates an output voltage out that is an exact image of the measured current IP .

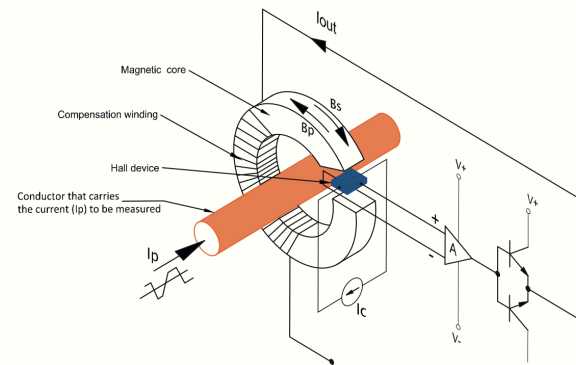

B_p	Magnetic flux by the input current
B_s	Magnetic flux by the output current
A	Amplifiers and signal conditioning to drive the output current
I_{out}	Output current which is proportional in the input current I_p
I_p	Conductor that carries the current (I_p) to be measured

Mechanical Features

- A wide range of primary current apertures
- PCB mounted or panel mounted
- Panel mounting with both horizontal and vertical positions
- Compact packages

Electrical Features

- Wide frequency range
- Good overall accuracy
- Fast response time
- Low temperature drift
- Excellent linearity
- No insertion losses

Applications

Industrial:

- Variable speed drives
- Uninterruptible Power Supplies (UPS)
- Active harmonic filters (Battery chargers, Wind generators, Solar inverters, etc.)

Railway:

- Main converters
- Auxiliary converters

Advantages

- High overload capability
- High reliability
- Excellent dynamic performance
- Galvanic isolation between the primary and secondary circuits
- Measurement of all waveforms is possible: direct current, alternating current, impulse, etc.
- High accuracy over a large frequency range (from direct current to 100 kHz)

TECHNOLOGY

Open Loop Hall-Effect Technology

Open loop current sensors measure direct, alternating & impulse currents, with galvanic isolation between the primary and secondary circuits. The primary current flowing in the sensor creates a proportional primary magnetic flux. A Hall device placed in the air gap of the magnetic core produces a Hall voltage (V_h) which is proportional to this flux as well as the current I_p being measured. An electronic circuit (A) amplifies this Hall voltage allowing it to be directly utilised in the end application measurement circuit as a secondary output voltage (V_s). The current sensor measures instantaneous values.

The secondary output voltage (V_s) is therefore directly proportional to the primary current. It is an exact replica of the primary current I_p , an exact replica of the primary current I_p , generally with a value of 4V for a nominal current I_{PN} .

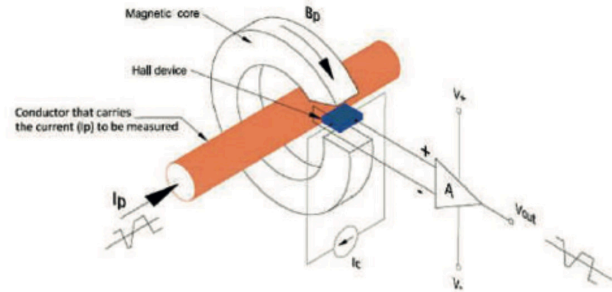

B_p	Magnetic flux by the input current concentrated by the core
A	Amplifiers and signal conditioning to drive the output voltage
V_{out}	Output voltage which is proportional to the input current I_p

Mechanical Features

- A wide range of primary current apertures
- PCB mounted or panel mounted or retrofit applications
- a range of split core sensor which can easily and securely be clamped onto the primary conductor
- Integrated primary conductor available on special order
- Panel mounting with both horizontal and vertical positions.
- Compact packages

Applications

- Variable speed drives
- Uninterruptible power supplies (UPS)
- Active harmonic filters
- Battery chargers
- Welding rectifiers

Advantages

The main advantages of this open-loop Hall Effect technology are as follows:

- Galvanic isolation between the primary and secondary circuits
- Measurement of all waveforms are possible:
 - Direct Current
 - Alternating Current
 - Impulse
- Good accuracy over a frequency range up to 50 kHz
- High reliability
- Reduced weight & volume
- Low power consumption
- Excellent cost/performance ratio

TECHNOLOGY

Closed Loop Voltage Transducers

The input current proportional to the measured voltage is applied to the sensor through current limiting input resistors. This current is driven through the primary coil of a sensor generates an output voltage proportionate to the measured voltage in the same principle as closed loop current sensors. In this, two different options are available for voltage measurement which are as follows:

- **VH Series** (*User specified input resistors*):

In this the user connects the input resistor in series with the sensor to limit the input current. The value of the input resistor R_1 is selected according to the voltage to be measured with due consideration to the maximum input current of the sensor. This approach allows for maximum flexibility.

- **VHASM series** (*Integrated input resistor*):

The value of integrated input resistor determines the nominal measuring voltage of the sensors. A wide selection of nominal voltage levels are offered to cover a variety of applications.

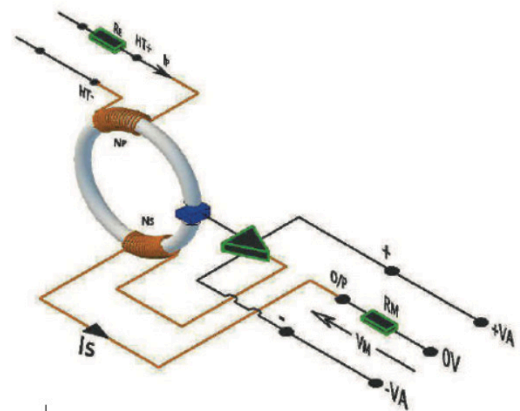

I_s	Secondary current
N_p	Primary turns
N_s	Secondary turns
V_m	Voltage across burden Resistance
R_m	Burden Resistance

Features

- Measurement of DC & low frequency voltages
- Galvanic isolation between input and output
- High accuracy
- Low temperature drift
- Good linearity

Applications

- Variable speed drives
- Uninterruptible power supplies (UPS)
- Active harmonic filters
- Battery chargers
- Welding rectifiers

Railway :

- Auxiliary converters (lighting, air conditioning, etc.)
- Battery chargers

TECHNOLOGY

High Isolation Voltage Sensors

Voltage sensors are suitable for measurement of DC and AC voltages with high galvanic isolation. These sensors are accurate and provide proportionate output signal to the applied input voltage for control electronics with high fidelity.

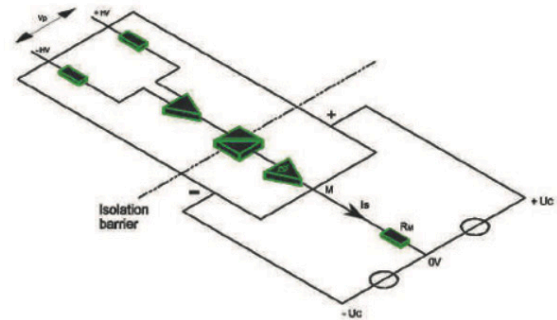

V_p	Primary voltage
V_n	Voltage across burden Resistance
R_m	Burden Resistance

Advantages

- Measurement of DC & AC voltages
- Good accuracy & linearity
- Low drift due to temperature
- Low power consumption
- High immunity to fast common mode voltage changes several
- Low sensitivity to electromagnetic disturbances
- Low output noise

Applications

- Variable speed drives
- Uninterruptible power supplies (UPS)
- Active harmonic filters
- Battery chargers
- Welding rectifiers

Railway:

- Auxiliary converters (lighting, air conditioning)
- Battery chargers

General Notes

Installation & Handling

- Ensure proper polarity of the power supply connection to avoid damage to the sensor.
- Ensure proper ESD practices when handling and installing the sensor. Static electricity or excessive voltage can damage the sensor.
- Avoid storing in high-temperature and high-humidity environment.
- For PCB mountable sensors used after a very long storage duration in a humid environment, please check the pins for solderability before mounting in assembly.
- It is recommended that the end user use mating connectors with equivalent terminal plating material to ensure long-term reliability and to avoid galvanic corrosion.

Signal Integrity

- In general, it is recommended that twisted or shielded cables should be used for output signals to reduce noise pickup.
- The sensor is sensitive to magnetic fields generated by other devices. In the presence of such fields, depending on their strength and vicinity, the accuracy may be impaired.
- It is recommended to centrally locate the current-carrying conductor or completely fill the central opening for optimum performance.
- Due to their principle of operation, closed-loop Hall-effect current sensors can be sensitive to strong magnetic fields. Avoid positioning them too close to high-current power cables.

Operating Limits

- Our specifications are guaranteed at specified input characteristics, supply voltage, temperature, etc. Some characteristics may change if these parameters are varied. Contact ElectrohmS for expected performance on parameters not mentioned in the datasheet.
- Nominal value is the input value at which the sensor operates continuously. Current applied above the maximum rated current can result in damage to the circuitry. Please contact ElectrohmS to determine overload specifications.
- Current drawn by the sensor is equal to no-load current plus compensation current. Ensure the power supply feeding the sensor has the required current capacity, inclusive of compensation current to the secondary winding.
- High-frequency primary current may result in excessive heating in the magnetic core and cause damage to internal circuitry. For high-frequency applications, select a current sensor with ferrite core material.
- If the measured current exceeds the rated current, magnetic core saturation will occur and the output signal will not be linearly proportional to the measured current.

Output & Calibration

- It is recommended to perform a zero-offset adjustment in the application circuit by measuring the offset voltage during installation.
- In the case of single supply voltage, the output signal varies around a nonzero value.
- We offer closed-loop sensors with standard output signals for specific applications on demand.

Warranty / Factory Settings

- Open-loop Hall sensors have offset and gain potentiometer settings sealed after factory setting. Removal of the sealant affects performance, and warranty claims will not be accepted.

Safety Instructions

This sensor must be used in electric/electronic equipment with respect to applicable standards and safety requirements in accordance with the manufacturer's operating instructions.

Electrical Shock Hazard

When operating the sensor, certain parts of the module can carry hazardous voltage (eg. primary busbar and power supply). **Ignoring this warning can lead to injury and/or cause serious damage.**



Installation Safety

Maintain safe separation between primary and secondary circuits across the full installation.

Thermal & Overcurrent Limits

Primary conductor temperature must not exceed 100° C. Overcurrents may create additional voltage offset due to magnetic remanence.

Protective Housing

Protect non-isolated high-voltage current-carrying parts against direct contact using a protective housing or shield.

Electrohms Private Limited
No. 67/6-1, Industrial Suburb,
Yeswanthpur, Bengaluru 560022

Telephone: +91 8043492200, 43492211 to 17
Fax: +91 80 23571852
Email: sales@electrohms.com

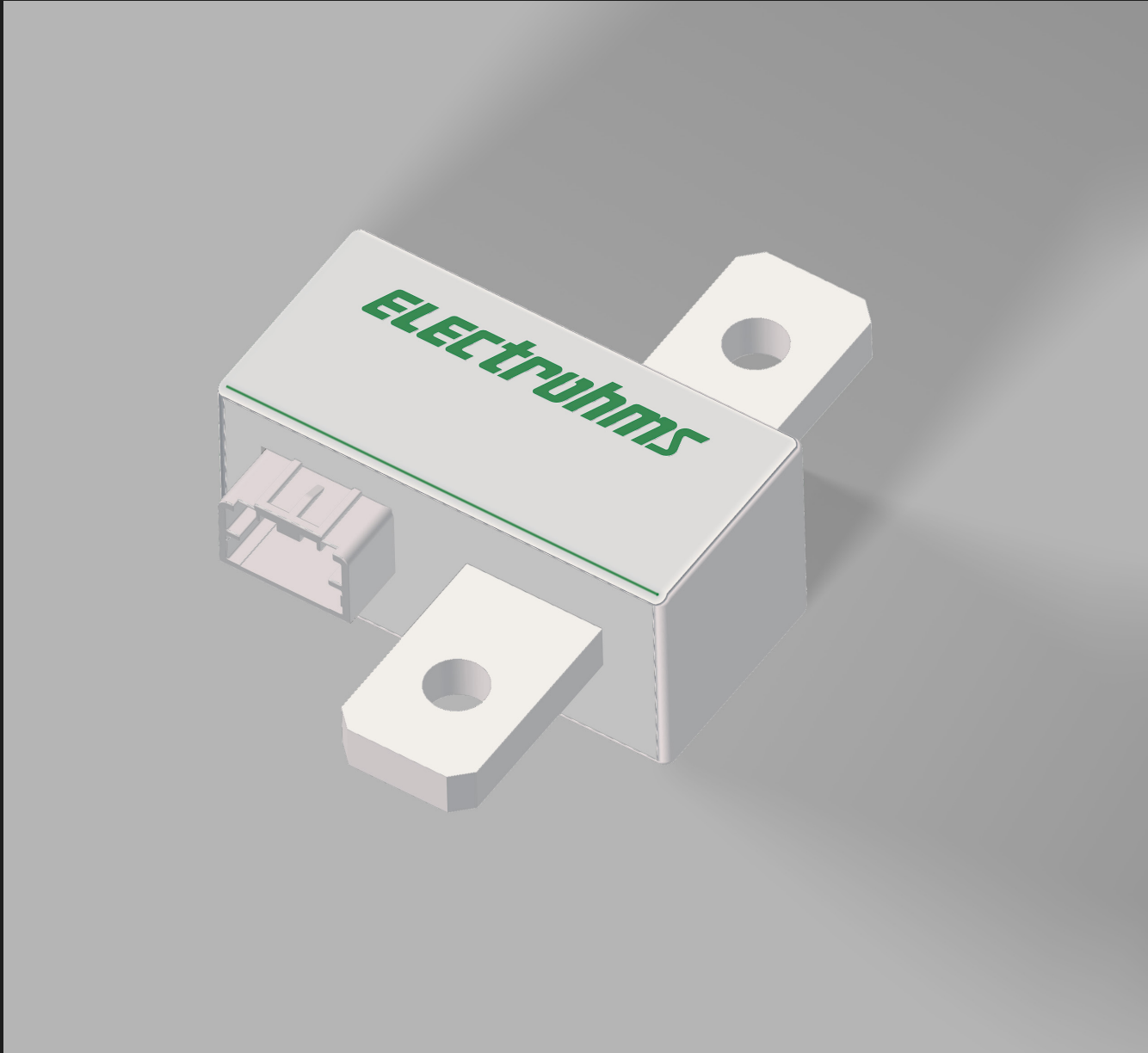

ELECTROHMS



We reserve the right to make technical changes or modify the contents of this document without prior notice. Electrohms does not accept responsibility for potential errors or omissions in this document. All rights are reserved in this document and in the subject matter and illustrations contained herein. Any reproduction, disclosure to third parties, or use of its contents, in whole or in part, is forbidden without prior written consent from Electrohms.