

 $I_{pn} = 200A$ 

Representative image only

Features

- Used for measurement of electric AC/DC current
- Open loop current sensor
- Pulsed in electric & electronic equipment
- Voltage output
- PCB mounting type
- Plastic outer case complaint to UL94-V0

Advantage

- Good linearity
- Low power consumption

Applications

- Used for measurement of electric DC current
- Pulsed in electric & electronic equipment

Application domain

- Industrial
- EV

Standards

- UL508*
- EN50178 (IEC 62477)
- IEC 62752
- AECQ qualified components

Insulation Characteristics

Parameters	Symbol	Value	Units
Dielectric strength between primary and secondary terminals,50 Hz, 60 seconds	V_d	1.5	kVrms
Comparative tracking index	CTI	600	V
Insulation resistance at 500 VDC	R_{IS}	>100	MΩ
Creepage distance		3.00	mm
Clearance distance		1.80	mm

Specifications (Unless otherwise specified temperature is 25°C)

Parameters	Symbol	Condition	Min	Typ	Max	Units
Primary Nominal Current	I_{pn}			200		Arms
Primary Measuring Range	I_p		-200		+600	A
Burden resistance	R_b		10			k Ω
Output offset voltage	V_{off}	at $I_p = 0$		1.50±0.015		V
Output voltage	V_{out}	at $\pm I_{pn}$, $R_b = 10k\Omega$		$V_{off} \pm 1.0$		V
Supply voltage	V_s		4.75	5.00	5.25	V
Current consumption	I_c	$V_s = +5V$		18.0		mA
Accuracy at I_{pn} (Excluding offset)	X_G		-1		+1	%
Linearity error	Σ_L		-1		+1	%
Temperature coefficient of V_{off}	TV_{off}	-40 to +85 °C	-0.5		+0.5	mV/K
Temperature coefficient of V_{out}	TV_{out}	-40 to +85 °C	-0.1		+0.1	%/K
Response time at 90% of I_{pn}	t_r			<10		μs
Frequency bandwidth	BW	-3dB, small signal bw	DC		50	kHz
di/dt accurately followed	di/dt			>50		A/ μs
Ambient operating temperature	T_A		-40		+125	°C
Ambient storage temperature	T_S		-40		+125	°C
Mass	m			25		g

Input & Output Characteristics

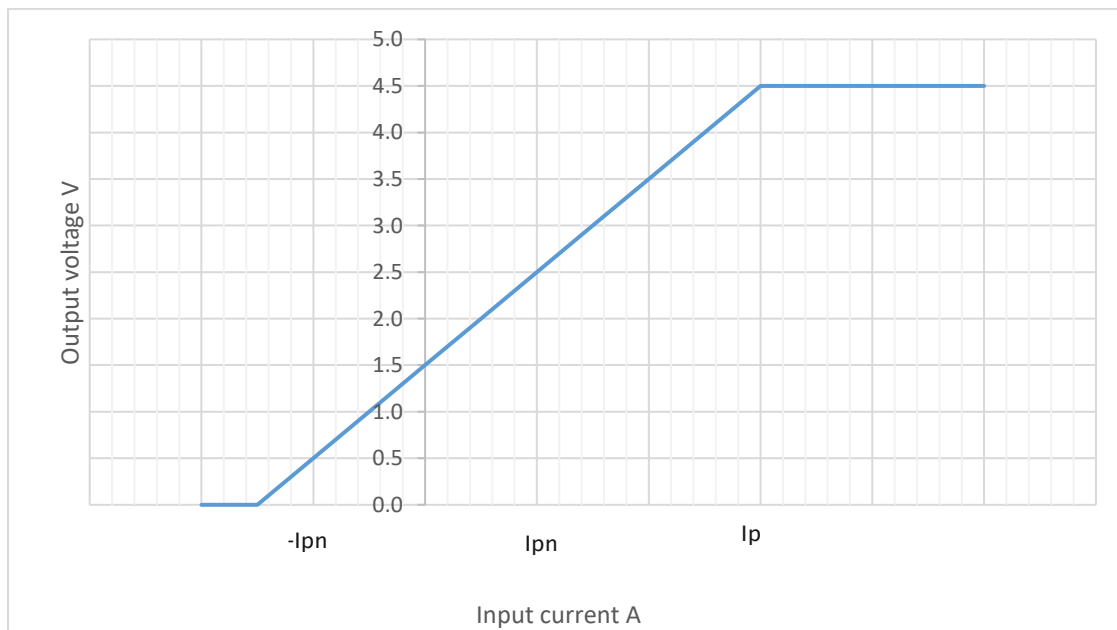

Mechanical dimensions

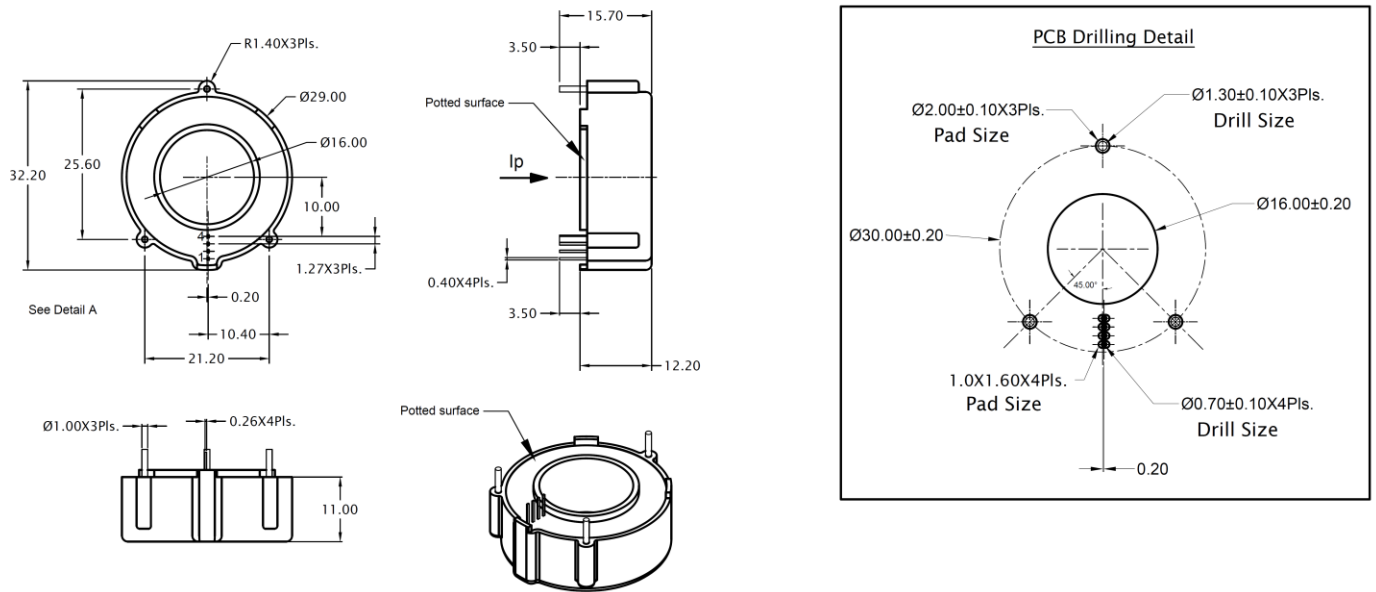

Tolerance unless otherwise specified

0.5 up to 3 in mm	3 up to 6 in mm	6 up to 30 in mm	30 up to 120 in mm	120 up to 400 in mm	400 up to 1000 in mm	ALL DIMENSIONS ARE IN 'mm'	
± 0.20	± 0.30	± 0.50	± 0.80	± 1.20	± 2.0	SCALE -NTS	

Connection Diagram

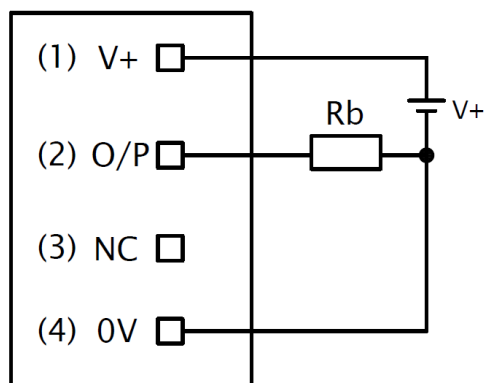

General information

- Sensor mounting: PCB mountable.
- It is recommended to centrally locate the current carrying conductor or completely fill the central opening for optimum performance.
- Output increases when current (I_p) flows in the direction of arrow.
- Ensure proper connection of power supply to avoid damage to the sensor.
- Electrohms reserves the right to make modifications on products for improvements without prior notice.
- * Designed to meet UL508

Safety



- This Sensor must be used in electric/electronic equipment with respect to applicable standards and safety requirements in accordance with the manufacturer's operating instructions.



- Caution, risk of electrical shock
- When operating the Sensor, certain parts of the module can carry hazardous voltage (eg. primary busbar, power supply).
- Ignoring this warning can lead to injury and/or cause serious damage.
- A protective housing or additional shield could be used
- Disconnecting the main power must be possible
- Over currents ($\gg I_{PN}$) can cause an additional voltage offset due to magnetic remanence.
- The temperature of the primary conductor shall not exceed 100 °C.
- This Sensors may only be used in electrical or electronic systems which fulfil the relevant regulations (Standards, EMC Requirements)
- Protect non-isolated high-voltage current carrying parts against direct contact (e.g. with a protective housing)
- When installing the sensor, ensure that the safe separation (between primary circuit and secondary circuit) is maintained over the whole circuits and their connections.